

TESTEQUITY

Model 123H Temperature/Humidity Chamber

With F4 Controller and EZ-Zone Limit, and HMM100 Humidity Sensor
Serial Number 230192 and above

Operation and Service Manual



TestEquity LLC
6100 Condor Drive
Moorpark, CA 93021

Support: 877-512-3457 Toll Free
805-480-0638

Corporate: 800-732-3457
805-498-9933

<http://www.testequity.com>

Table of Contents

Chapter 1 – Safety Instructions	1-1
Introduction	1-1
Installation Safety Notices	1-1
Operation Safety Notices	1-2
Chapter 2 – Installation	2-1
Uncrating	2-1
Preparation For Use	2-1
Installation Location	2-2
Humidity Water Connection	2-3
Plumbed Demineralized Water Installation	2-3
Water Recirculation System Installation	2-3
Water Recirculation System Filter Cartridge Replacement	2-3
Water Recirculation System Assembly	2-4
Chapter 3 – Operation	3-1
Introduction	3-1
Summary of Chamber Operation	3-1
Front Panel Switches and Lights	3-2
Power Switch	3-2
Conditioning Switch – ON Mode	3-2
Conditioning Switch – Event 1 Mode	3-2
Light Switch	3-2
Heat Light	3-2
Cool Light	3-2
Humidity Enable Light	3-3
Humidity Light	3-3
Loading the Chamber	3-4
Performance Considerations	3-4
Port Plugs	3-5
Avoiding Moisture (non-humidity mode)	3-5
Internal Test Fixtures	3-5
Chapter 4 – F4 Temperature/Humidity Controller	4-1
Introduction	4-1
Security Features	4-1
F4 Controller Keys and Displays	4-2
Main Page	4-3
Static Set Point Control	4-4
Humidity Operation	4-5
Humidity Mode Enable	4-5
Standard Humidity Range	4-6
Humidity Mode Considerations	4-6
System Enable Function	4-7
Event Outputs for Customer Use	4-8
Event Assembly	4-8
Purge	4-9
GN2 (Gaseous Nitrogen) Installation	4-9
Dry Air Installation (TE-0017)	4-9
Purge Operation	4-10
Adjusting the Purge Flow	4-10
Relief Vent	4-10

Table of Contents

Profile Programming	4-11
Step Types	4-11
How to Program a New Profile	4-13
Programming Hints	4-14
Profile Key	4-14
How to Start a Profile	4-14
How to Hold/Resume a Running Profile	4-15
How to Terminate a Running/Holding Profile	4-15
How to Delete or Re-Name a Profile	4-15
How to Edit a Profile	4-16
Profile Examples	4-17
Operations Page	4-18
Setup Page	4-18
Factory Page	4-19
Computer Interface	4-19
RS-232C	4-19
Common Modbus Registers	4-19
GPIB (optional)	4-19
Ethernet (optional)	4-19
Chapter 5 - Limit Controller	5-1
Introduction	5-1
Limit Controller Keys and Displays	5-2
How to Set the High and Low Temperature Safety Limits	5-2
Resetting an Out of Limit Condition	5-2
Silencing the Audible Alarm	5-2
Protecting an Energized Test Sample	5-3
Chapter 6 – Frequently Asked Questions	6-1
Chapter 7 – Specifications	7-1
Model 123H Chamber Specifications	7-1
F4 Controller Specifications	7-2
Chapter 8 – Maintenance	8-1
Preventive Maintenance Intervals	8-1
Daily or As Needed	8-1
Every 3 Months	8-1
Every 6 Months	8-1
Every 12 Months	8-1
Maintenance Procedures	8-2
How to Clean the Chamber Interior and Exterior	8-2
How to Listen for Abnormal Noise or Vibration	8-2
How to Inspect the Door Seal	8-2
How to Inspect the Refrigeration Machinery Compartment	8-3
How to Verify the Performance (Non-controlled humidity mode)	8-4
How to Verify the Performance (Controlled humidity mode)	8-5
How to Inspect the Electrical Compartment	8-6
How to Clean the Condenser	8-6
How to Drain the Humidity System	8-6
How to Verify the Temperature Calibration	8-7
How to Verify the Humidity Calibration	8-7
Humidity Sensor Calibration and Maintenance	8-8
How to Verify the F4 Controller’s Input 2 (Humidity Input) Calibration	8-8

Table of Contents

Theory of Operation	8-9
Overview	8-9
Air Heating System	8-9
Humidity System	8-9
Refrigeration System (non-humidity mode)	8-10
Refrigeration System (controlled-humidity mode)	8-11
Troubleshooting	8-12
Refrigeration System Charging Instructions	8-14
R-404A High-Stage Charge	8-14
R-508B Low-Stage Charge	8-14
Recommended Spare Parts	8-15
Major Electrical Parts	8-16
Major Refrigeration Parts	8-17
General Parts	8-17
Series F4 Controller Setup Parameters	8-18
Series F4 Setup Parameters	8-19
Series F4 Operations Parameters	8-20
Series F4 Set Lockout Parameters	8-20
EZ-Zone Limit Controller Setup Parameters	8-21
Setup Menu	8-21
Operations Menu	8-21
Chapter 9 - Warranty	9-1
Chapter 10 – Drawings	10-1

Chapter 1 – Safety Instructions

Introduction

Follow all CAUTION notices to prevent damage to the chamber or your test sample. Failure to follow all CAUTION notices may void your warranty. CAUTION may also indicate a potentially hazardous situation which, if not avoided, may result in minor or moderate personal injury.

WARNING indicates a potentially hazardous situation which, if not avoided, could result in death or serious injury.

The safety alert symbol  precedes a general CAUTION or WARNING statement.

The electrical hazard symbol  precedes an electric shock hazard CAUTION or WARNING statement.

Installation Safety Notices

 **WARNING:** The power cord is equipped with a NEMA 5-20P grounded/polarized plug. To prevent a shock hazard, DO NOT defeat the ground or polarization feature. This device MUST be plugged DIRECTLY into a properly grounded and polarized NEMA 5-20R receptacle. Due to high current demand on start-up, use of an extension cord is NOT recommended.

 **CAUTION:** The minimum clearance you should allow for proper ventilation around the chamber must be at least 6" from both the left and right side, and 12" from the rear.

 **CAUTION:** This chamber is designed for operation in a conditioned laboratory environment. Operation above 30°C (85°F) or below 16°C (60°F) ambient room temperature is NOT recommended.

Operation Safety Notices

- △ **CAUTION:** The “Series F4 User’s Manual” is a general manual and is written by the manufacturer, Watlow, for a wide variety of applications and configurations. Not all features or functions are applicable. Only the capabilities of a model F4DH-CKCC-01, as described on page A.7 of the “Series F4 User’s Manual” are applicable. “Cascade Control” as described on page 3.6 of the “Series F4 User’s Manual” is not applicable in this configuration. The “Retransmit” function is available as an option.
- △ **CAUTION:** The Series F4 alarms are configured for internal protection of the humidity system. Do NOT change this configuration under any circumstances. The independent EZ-Zone Limit Controller functions as the main system and product protection device.
- △ **CAUTION:** The Series F4 Controller has been properly configured by TestEquity to match the chamber’s system requirements and to perform optimally over a wide range of operating conditions. Improper modifications to these setup values can result in erratic performance and unreliable operation. Setup examples in the “Series F4 User’s Manual” are NOT applicable to this chamber. Do not attempt to modify the setup values, unless you thoroughly understand what you are doing. If there is any doubt, please call TestEquity before proceeding.
- △ **CAUTION:** NEVER select “Full Defaults” in the Series F4 Controller’s Factory/Test Menu. This will erase all the correct values which are documented in the “Series F4 Controller Setup Parameters” section of this manual.
- △ **CAUTION:** The EZ-Zone Limit Controller has been properly configured by TestEquity to match the chamber’s system requirements. Improper modifications to these setup values can result in unreliable and unsafe operation. Do not attempt to modify the setup values, unless you thoroughly understand what you are doing. The correct values are documented in the “EZ-Zone Limit Controller Setup Parameters” section of this manual.
- △ **CAUTION:** Always verify that the Limit Controller’s high and low limits are set to temperatures that are appropriate for your test sample.
- △ **CAUTION:** If your test sample is energized, it may be capable of raising the workspace temperature beyond safe limits. This could occur if your test sample exceeds the live load rating of the chamber or if the chamber’s refrigeration system fails. This chamber has a set of contacts that can be used to remove power to your test sample if the Limit Controller’s temperature limits are exceeded.
- △ **CAUTION:** To prevent damage to your test sample and the chamber’s compressors, do not exceed the live load rating of the chamber.

Chapter 1 – Safety

- ⚠ **WARNING:** Do NOT put items in the chamber that could burn or explode at high temperatures. This chamber uses open wire heating elements which generate surface temperatures over 1000°F. This is NOT an explosion-proof chamber.

- ⚠ **WARNING:** Do NOT put items in the chamber which can emit corrosive vapors or substances.

- ⚠ **WARNING:** This chamber is NOT a curing oven. There are NO provisions for venting fumes.

- ⚠ **WARNING:** The chamber door must remain closed while the chamber is operating. If you need to open the door while the chamber is operating, wear safety goggles to prevent the high velocity airflow from blowing particles or objects into your eyes.

- ⚠ **WARNING:** This chamber operates at extreme temperatures. Avoid contact with air, objects, and surfaces that are hot or cold to prevent severe burns or frostbite. Protective gloves are recommended.

Chapter 2 – Installation

Uncrating

Inspect the shipping container for any signs of visible damage. Notify the carrier and TestEquity immediately if there are signs of shipping damage.

The pallet is designed with ramps so the chamber can be rolled off without the need for a forklift or pallet jack.

1. Cut the two metal bands that hold the packaging to the pallet.
2. Remove the top cover.
3. Remove the plastic fasteners that hold the outer box together and remove the outer box.
4. Locate the retainer in the front of the pallet. Remove the two screws, then remove the retainer. Keep in mind that there is also Velcro that holds the retainer in place. Place the retainer in the front of the pallet on the floor.
5. Locate the two ramps under the chamber and remove them.
6. Attach the ramps to the front of the pallet using the Velcro straps. The retainer will be under the ramps and act as a support.
7. Carefully roll the chamber off the pallet, onto the ramps. This should be done with at least two people.

Preparation For Use

1. Inspect the chamber for signs of shipping damage.
2. Read this entire manual.
3. Select a suitable location to install the chamber.
4. Connect to the power source.
5. Perform following the procedures as described in the Preventive Maintenance section:
 - a. Inspect the electrical compartment.
 - b. Inspect the refrigeration machinery compartment.
 - e. Verify the chamber performance.

Installation Location

The chamber will produce a significant amount of heat during normal operation. Locate the chamber in a room with adequate ventilation to prevent excessive heat build-up. The chamber generates a heat load of up to 5,000 btuh during a continuous cool down from a high temperature.

The chamber must be on a solid and level floor. Allow enough space around the chamber to permit serviceability and the removal of the service access panels, which are located on each side and the rear.

△ CAUTION: The minimum clearance you should allow for proper ventilation around the chamber must be at least 6" from both the left and right side, and 12" from the rear.

△ CAUTION: This chamber is designed for operation in a conditioned laboratory environment. Operation above 30°C (85°F) or below 16°C (60°F) ambient room temperature is NOT recommended.

Humidity Water Connection

⚠ CAUTION: The humidity system must be supplied with demineralized water having a specific resistance of 50,000 to 200,000 ohms/centimeter. The use of unfiltered tap water or triple-distilled water will damage the humidity system and chamber interior, and will void the warranty.

Plumbed Demineralized Water Installation

Follow these instructions if your chamber is NOT being used with the optional water recirculation system, and you are connecting to a plumbed source of demineralized water.

1. Attach a supply of demineralized water to the Water Supply fitting on the rear of the chamber.
2. The chamber drain water is not under pressure, and is fed by gravity. Therefore, it must empty into an open floor drain. Alternatively, the chamber drain can empty into a condensate pump. You can purchase a condensate pump from suppliers such as Grainger (www.grainger.com).

Water Recirculation System Installation

The optional water recirculation system provides a source of demineralized water for the humidity system, using ordinary tap or pre-filtered water. Condensate from the chamber is returned back to the water tank. The pump operates only when needed to fill the chamber's humidifier to the correct level. All water connections should be finger-tight only – do not use a wrench. Detailed assembly pictures are shown on the next page.

1. Attach filter cartridge. Use clamp provided on each end of filter to prevent leaking. Do not overtighten.
2. Position the recirculation system on the back left side of the chamber.
3. Attach the pump outlet hose to the bottom fitting of the filter.
4. Place the pump in the water tank.
5. Attach the chamber Water Supply hose from the chamber to the top fitting of the filter.
6. Attach the chamber Drain hose to the chamber and position it so it goes into the water tank.
7. Fill the water tank with clean water.
8. Place the cover on the water tank.
9. Plug the pump electrical line into the receptacle labeled Pump on the rear of the chamber.

Water Recirculation System Filter Cartridge Replacement

The demineralizer filter cartridge must be replaced when it is used up. The color of the bottom half of the cartridge changes gradually through continued use. Replacement cartridges are available from TestEquity (part number TE-0014 for a carton of 6 cartridges).

The demineralizer filter cartridge will last longer if pre-filtered water is used, although this is not a requirement. Rather than filling the recirculation system reservoir with tap water, you can use filtered drinking water (not spring water).

Water Recirculation System Assembly



Use clamp on each end of filter to prevent leaking. Do not overtighten.



Pump placement in water tank.

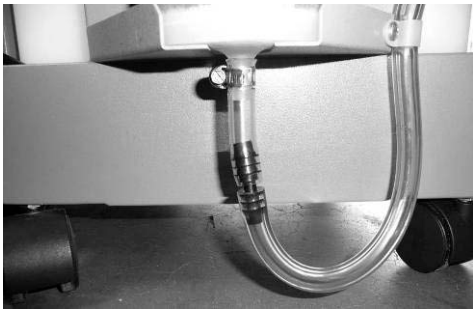

Finger-tighten the Water Supply and Drain connections to chamber. Plug pump wire into receptacle, turn clockwise to lock. Drain tube must not be submerged in the water. Installation behind chamber is not recommended because it may block the air vents.



Chapter 3 – Operation

Introduction

The Front Panel Switches control power to the chamber. The Front Panel Lights provide indication of heat and cool functions.

The EZ-Zone Limit Controller is a protection device. It turns the chamber OFF if the workspace temperature exceeds either a high temperature or low temperature limit set point.

The F4 Controller controls the temperature and humidity of the chamber. It can function as either a single set point controller or as a programmable profile controller. The F4 Controller automatically turns the refrigeration system on or off based on the demand for cooling.

Summary of Chamber Operation

1. Turn the Power Switch ON.
2. Enter the appropriate high and low temperature safety limits on the Limit Controller.
3. Enter the desired set points (or program) on the F4 Controller.
4. Load your test sample in the chamber.
5. If you are running a controlled humidity condition between +10°C and +85°C, turn Event 2 ON.
6. If you are running temperature conditions lower than +10°C or greater than +85°C, turn Event 2 OFF. Humidity cannot be controlled in this mode.
7. Turn the Conditioning Switch ON.

Front Panel Switches and Lights

Power Switch

The Power Switch controls power to the entire chamber. The Power Switch illuminates when it is ON.

Conditioning Switch – ON Mode

The Conditioning Switch enables all chamber functions. When the Conditioning Switch is OFF and the Power switch is ON, only the F4 Controller and Limit Controller are operational. When both the Power and Conditioning Switches are ON, the chamber's conditioning system will function to maintain the temperature/humidity set point. The Conditioning Switch does not illuminate.

Conditioning Switch – Event 1 Mode

When the Conditioning Switch is in the Event 1 position, you can enable and disable all chamber functions through Event 1 (Digital Output 1) of the F4 Controller. When the Conditioning Switch is in the Event 1 position and Event 1 on the F4 Controller is Off, all chamber functions are disabled. If Event 1 is On, all chamber functions are enabled.

See page 4-7 for instructions on how to control the events in manual mode. In profile mode, Event 1 is named **CONDITION**.

⚠ CAUTION: Remember to set **DigitalOut 1 (Event Output1)** to **On** in static set point mode when the chamber is to be operational. In this mode, the Modbus register for Digital Output 1 is 2000.

⚠ CAUTION: Remember to set **CONDITION** to **On** in the profile event prompt for all programmed steps when the chamber is to be operational.

Light Switch

The Light Switch controls the workspace light. The Light Switch illuminates when it is ON.

Heat Light

The Heat Light will illuminate when the F4 Controller turns on the heater to maintain the workspace temperature. The Heat Light will cycle on/off as the workspace temperature approaches and reaches the temperature set point. This light corresponds to the 1A indicator on the F4 Controller.

Cool Light

The Cool Light will illuminate when the F4 Controller turns on the cooling valve to maintain the workspace temperature. The Cool Light will cycle on/off as the workspace temperature approaches and reaches the temperature set point. This light corresponds to the 1B indicator on the F4 Controller.

Humidity Enable Light

The Humidity mode is enabled through Event 2 (Digital Output 2) in the F4 Controller. Event 2 should ONLY be ON if you are performing a controlled humidity test within the humidity range of the chamber (+10°C and +85°C).

If Event 2 is OFF, the Humidity mode is disabled. The chamber will cool in cascade mode (both compressors running).

If Event 2 is ON, the Humidity mode is enabled and the Humidity Enable light will be illuminated, as long as the chamber temperature is within +7°C and +90°C. The chamber will cool in single-stage mode (one compressor running).

Humidity Light

The Humidity Light will illuminate when the F4 Controller turns on the humidifier heater to maintain the workspace humidity. The Humidity Light will cycle on/off as the workspace humidity approaches and reaches the humidity set point. This light corresponds to the 2A indicator on the F4 Controller.

Note that the Humidity Enable Event 2 must be ON, the chamber workspace must be between +7°C and +90°C, and the humidifier water level must be correct for the Humidity Light to correspond to the 2A indicator on the F4 Controller.

The 2B indicator on the F4 Controller lights when dehumidification is required to maintain the workspace humidity. There is no corresponding pilot light on the front panel for this function.

Loading the Chamber

- ⚠ **WARNING:** Do NOT put items in the chamber that could burn or explode at high temperatures. This chamber uses open wire heating elements which generate surface temperatures over 1000°F. This is NOT an explosion-proof chamber.
- ⚠ **WARNING:** Do NOT put items in the chamber which can emit corrosive vapors or substances.
- ⚠ **WARNING:** This chamber is NOT a curing oven. There are NO provisions for venting fumes.
- ⚠ **WARNING:** The chamber door must remain closed while the chamber is operating. If you need to open the door while the chamber is operating, wear safety goggles to prevent the high velocity airflow from blowing particles or objects into your eyes.
- ⚠ **WARNING:** This chamber operates at extreme temperatures. Avoid contact with air, objects, and surfaces that are hot or cold to prevent severe burns or frostbite. Protective gloves are recommended.
- ⚠ **CAUTION:** If your test sample is energized, it may be capable of raising the workspace temperature beyond safe limits. This could occur if your test sample exceeds the live load rating of the chamber or if the chamber's refrigeration system fails. This chamber has a set of contacts that can be used to remove power to your test sample if the Limit Controller's temperature limits are exceeded.
- ⚠ **CAUTION:** To prevent damage to your test sample and the chamber's compressors, do not exceed the live load rating of the chamber.

Live Load Capacity for Model 123H

Temp	+23°C	0°C	-40°C	-55°C	-65°C
Watts	500 W	400 W	225 W	175 W	100 W

Performance Considerations

The performance of all chambers is significantly affected by the characteristics of your test sample. Factors include size, weight, material, shape, and power dissipation if energized. The test sample should be placed in the chamber in a manner that allows for air circulation. The air plenum is located on the back wall of the chamber, where air is sucked in from the bottom and exits from the top. You should not place the test sample directly on the chamber floor. It should be placed on the shelf. Multiple test samples should be distributed throughout the chamber to ensure even airflow and minimize temperature gradients. If necessary, additional shelves should be used to evenly distribute the load. Verify that the temperature gradients are within acceptable limits, by measuring the chamber temperature at strategic points using a multipoint thermocouple meter or data logger.

You may find that the temperature throughout the chamber is even, but always different from what the F4 Controller indicates. The correct way to adjust what the F4 Controller “displays” compared to what is measured at some point other than the controller’s sensor is with the “Calibration Offset” parameter, NOT by recalibrating the controller.

Port Plugs

Foam port plugs are provided with a gray silicone surface on one side. The port plug must be inserted with the gray silicone surface facing the inside of the chamber. Port plugs should be considered expendable and be replaced when they no longer provide a good seal.

Avoiding Moisture (non-humidity mode)

Any time the ambient air is subjected to temperatures below the dew point, moisture will condense out of the air. The effect is ice or frost during low temperature operation, or water when maintaining over 0°C and cooling is required.

To avoid moisture condensation, make sure the port plugs are inserted at all times. Also, avoid opening the chamber door while the chamber is operating at temperatures below room ambient. When a low temperature test is completed, warm the chamber to at least room ambient before opening the chamber door and before removing your test sample.

You CANNOT use the humidity system to control moisture at low temperatures. The humidity system is disabled below +7°C. However, if you have a source of GN₂ (gaseous nitrogen) or Dry Air, you can use the Purge system to eliminate moisture condensation at low temperatures.

Internal Test Fixtures

Some applications require internal fixtures to support test samples and provide a convenient method of connecting wires and sensors. Fixtures must be designed to minimize their impact on chamber functionality and performance.

Fixtures should be designed for easy removal to permit maintenance and cleaning of the chamber. The chamber liner should never be drilled or screwed into. This will compromise the integrity of the liner and permit moisture migration due to condensation into the insulation, which will eventually impact performance and lead to premature rusting of the outer cabinet.

Fixtures should be constructed of stainless steel. This also applies to all screws and fasteners. All welds should be passivated. To prevent rust and corrosion, never use iron or mild steel even if it is painted or plated. Aluminum may be used. However, since the specific heat of aluminum is double that of steel, it represents a greater load and will have more impact on the chamber performance.

Make sure that all connectors, wiring, pc boards, and auxiliary components can withstand the temperature extremes that they will be subjected to. In some cases, these components may not be able to last after repeated tests and should be considered expendable.

Chapter 4 – F4 Temperature/Humidity Controller

Introduction

The Series F4 Controller can function as either a single set point controller (static mode) or as a programmable profile controller. A four-line LCD display facilitates setup and programming, and presents informative messages about status, error, and alarm conditions. An Information Key gives you quick information about the pages, menus, parameters and values, as well as error and alarm conditions if they occur. The user-interface is organized into five “pages” of menus.

⚠ CAUTION: The Series F4 alarms are configured and dedicated for internal protection of the humidity system. Do NOT change their configuration under any circumstances. The independent EZ-Zone Limit Controller functions as the main protection device.

⚠ CAUTION: The Series F4 Controller has been properly configured by TestEquity to match the chamber’s system requirements and to perform optimally over a wide range of operating conditions. Improper modifications to these setup values can result in erratic performance and unreliable operation. Do not attempt to modify the setup values, unless you thoroughly understand what you are doing. Setup examples in the “Series F4 User’s Manual” are NOT applicable to this chamber. If there is any doubt, please call TestEquity before proceeding. The correct values are documented in the “Series F4 Controller Setup Parameters” section of this manual.

⚠ CAUTION: NEVER select “Full Defaults” in the Series F4 Factory/Test Menu. This will erase all the correct values which are documented in the “Series F4 Controller Setup Parameters” section of this manual.

Security Features

The Series F4 Controller has several levels of security to prevent unauthorized users from changing critical configuration parameters. Only the Set Point and Profile menus have “Full Access”. TestEquity has configured the security of all other menus to “Password”, and have protected them with a password.

TestEquity does not recommend that these security levels be changed for most applications. However, there will be times when entry into these menus is necessary. For example, you may need to gain access to Setup Page in order to change from °C to °F display, or to change the time or date. You must call TestEquity at 877-512-3457 or 805-480-0638 to obtain the password.

F4 Controller Keys and Displays

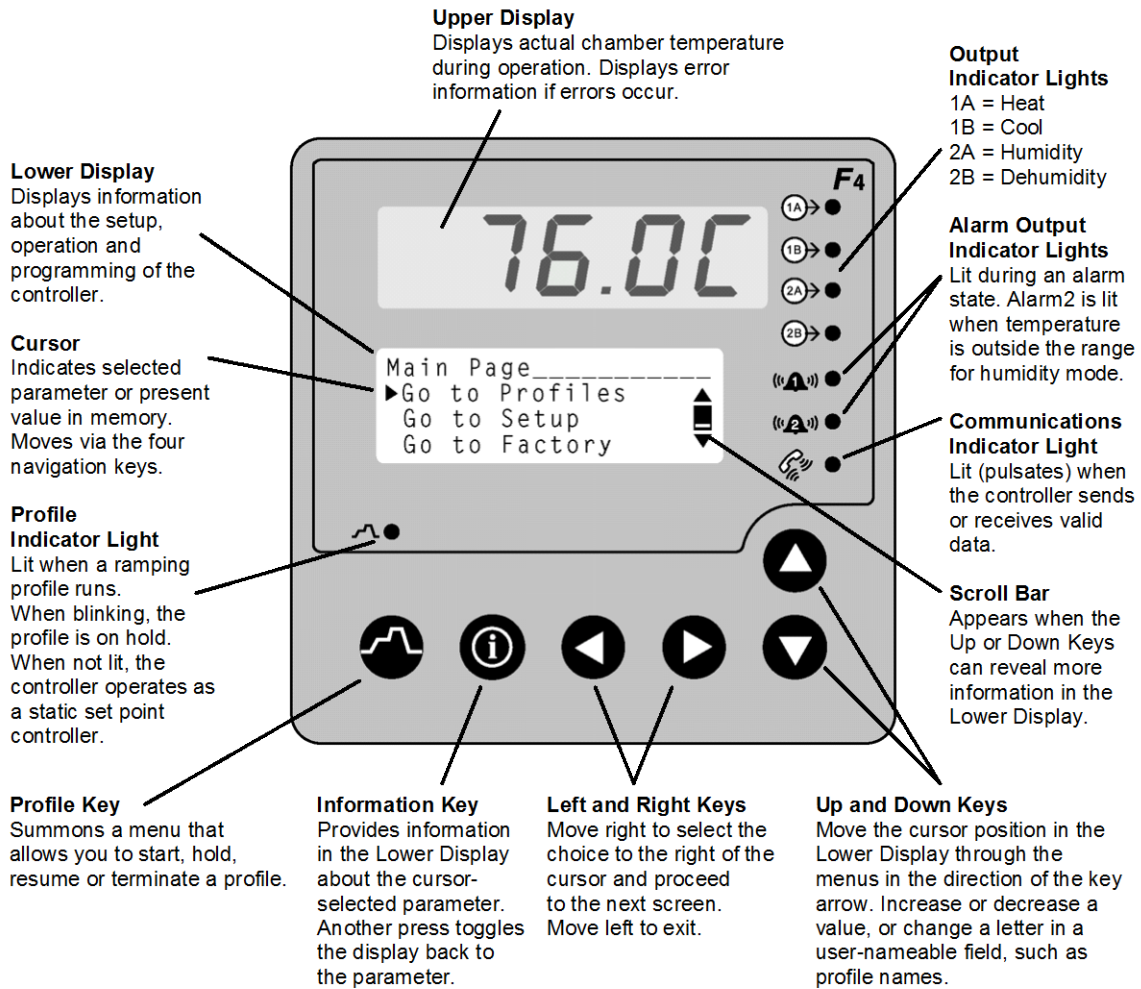

Figure 4.1 – F4 Controller Keys and Displays

To navigate through the menus:

1. Use the ▲ or ▼ key to move the cursor to line up with the item to be selected in a menu on the lower display.
2. Press the ► key to select the item.
3. Enter or change the value, or make a choice with the ▲ or ▼ key.
4. Press the ► key to enter the value or choice.
5. Repeat until you return to the original list.

The ► key again saves the value and proceeds to the next parameter in the series.

The ◀ key saves the value and backs out of the series, and returns to the Main Page.

To edit a parameter, proceed through the series using the ► key without changing values until you find the parameter you want to change. After making the change with the ▲ or ▼ key, you may back using the ◀ key out or proceed using the ► key to the end of the series.

Main Page

The Main Page displays manual operating parameters, running program parameters and error messages. It also provides access to the Operations, Profiles, Setup and Factory pages. The following is a list of Main Page parameters and the description of their functions.

Main Page

Input 2	The actual chamber workspace humidity (%RH).
Current File	Displayed if running a profile, the name of the profile.
Current Step	Displayed if running a profile, the current step of the profile.
▶ SP1	Static (manual) temperature set point entry. If running a profile, the current set point.
SP2	Static (manual) humidity set point entry. If running a profile, the current set point.
Step Type	Displayed if running a profile, the type of step.
Target SP1	Displayed if running a profile, the target temperature during a ramp step.
Target SP2	Displayed if running a profile, the target humidity during a ramp step.
WaitFor Status	Displayed if running a profile, the status during a WaitFor step.
Jump Count	Displayed if running a profile, the number of jumps completed.
Time Remaining	Displayed if running a profile, the remaining time of the current step.
DigitalOut	Status of digital outputs 1 through 8. An “8” indicates when cooling system is ON.
Power1	The % of throttle of the heat (+ number) or cool (– number) output.
Power2	The % of throttle of the humidity (+ number) or dehumidify (– number) output.
Date	Real-time clock date.
Time	Real-time clock time.
Go to Operations	Access to Operations Page
Go to Profiles	Access to Profiles Page
Go to Setup	Access to Setup Page. Not displayed if running a profile.
Go to Factory	Access to Factory Page. Not displayed if running a profile.

Static Set Point Control

The F4 Controller is in Static Mode when it is not controlling a Profile. When in a Static Mode, the Profile Indicator Light is off (see Fig. 4.1). The Upper Display shows the actual chamber workspace temperature. The Static Set Point prompts are accessed from the Main Page.

To enter a Static Temperature Set Point:

1. Press the ▲ or ▼ key to position the Cursor next to the SP1 prompt. You may already be at this prompt.
2. Press the ► key once. You will see **Static Set Point1** in the lower display with the current set point indicated below.
3. Press the ▲ or ▼ key to change the temperature set point value.
4. Press the ► key once to enter the new temperature set point. You are now back to the Main Page.

Main Page _____	Static Set Point1: _____
Input2 85.0% ▲	85.0 °C
► SP1 85.0 °C ■	▲
SP2 85.0% ▼	▼ Adjusts Value
	◀ Back ▶ Next

To enter a Static Humidity Set Point:

1. Press the ▲ or ▼ key to position the Cursor next to the SP2 prompt. You may already be at this prompt.
2. Press the ► key once. You will see **Static Set Point2** in the lower display with the current set point indicated below.
3. Press the ▲ or ▼ key to change the humidity set point value.
4. Press the ► key once to enter the new temperature set point. You are now back to the Main Page.

Main Page _____	Static Set Point2: _____
Input2 85.0% ▲	85.0 %RH
SP1 85.0 °C ■	▲
► SP2 85.0% ▼	▼ Adjusts Value
	◀ Back ▶ Next

Humidity Operation

Humidity Mode Enable

The Humidity mode is enabled through Event 2 (Digital Output 2) in the F4 Controller. Event 2 should ONLY be ON if you are performing a controlled humidity test within the humidity range of the chamber (see following page).

NOTE: The Modbus register to program Digital Output 2 in static set point mode is 2010.

NOTE: In the Profile Create and Edit menus, Digital Output 2 is named HUMIDITY. Remember to set HUMIDITY to On in all programmed steps when the chamber is to be in the controlled humidity mode.

To Enable or Disable the Humidity Mode in static set point mode:

1. The F4 Temperature Controller must first be on the Main Page. Press the ▲ or ▼ key to position the Cursor next to the DigitalOut prompt.
2. Press the ► key once. You will see Choose Event Output prompt in the lower display. Press the ▲ or ▼ key to position the Cursor next to Event Output2.
3. Press the ► key once to select Event Output2. Then, press the ▲ or ▼ key to select On or Off.
4. Press the ► key once to return to the Choose Event Output prompt.
5. Press the ◀ key once to return back to the Main Page. You will see a 2 in the DigitalOut line if Event2 is ON.

```
Main Page_____
  SP1          85.0°C ▲
  SP2          85.0% ■
  ► DigitalOut_____ ▼
```

```
Choose Event Output_
  Event Output1
  ► Event Output2   ■
  Event Output3     ▼
```

```
Event Output2_____
  Off
  ► On
```

```
Main Page_____
  SP1          85.0°C ▲
  SP2          85.0% ■
  ► DigitalOut_2_____ ▼
```

Standard Humidity Range

This chamber is capable of controlling humidity from 10% RH to 95% RH over the temperature range of +10°C to +65°C, and up to 90% RH from over +65°C to +85°C. The lowest possible humidity varies depending on the temperature, and is limited to a 6°C dewpoint. For example, +45°C is the lowest temperature that 10% RH can be achieved. Below is a chart that shows the achievable range of humidity as compared to temperature. Achieving low humidity levels require you to start with a clean, dry chamber. For extended low humidity range, see “Purge Option” which follows.

To protect the chamber, the F4 Controller’s Alarm 2 will disable the humidity system below +7°C and above +90°C.

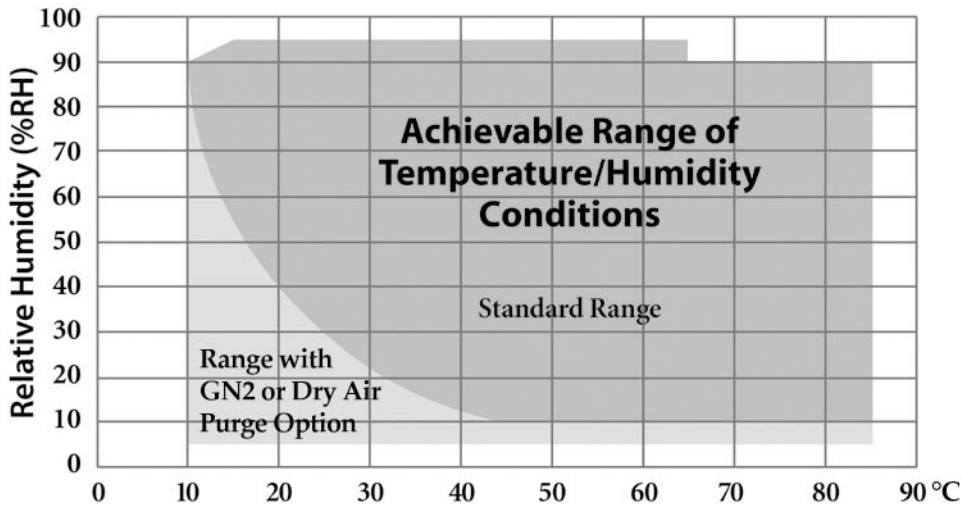

Figure 4.2 – Achievable Range of Temperature/Humidity Conditions

Humidity Mode Considerations

The Humidity mode is enabled through Event 2 (Digital Output 2) in the F4 Controller. Event 2 should ONLY be ON if you are performing a controlled humidity test within the humidity range of the chamber. Also, the chamber workspace must be between +7°C and +90°C. If the chamber is outside this temperature range, the F4 Controller’s Alarm2 light will turn ON and the chamber will operate as though the Humidity Enable was OFF.

It takes several minutes for the humidifier to fill to the correct level after the water supply is initially connected to an empty system. The humidifier function is disabled until the water level is correct.

If you are running a high humidity condition, it can take approximately 5-10 minutes until the humidifier heats up from an initial “cold start”. During most of that time, it might appear that “nothing is happening” because there is little increase in the humidity reading (the Input2 prompt) on the F4 Controller. Be patient – if the Humidity Light is ON, the humidity will eventually begin to rise after this initial heat-up period.

System Enable Function

The chamber can be configured to enable or disable all chamber functions through Event 1 (Digital Output 1) in the F4 Controller. The Conditioning Switch needs to be in the Event 1 position. This configuration may be desirable if you want to turn off all chamber function at the end of a programmed profile, or through the communications interface.

All chamber functions will be disabled if Event 1 is Off. If Event 1 is On, all chamber functions will be enabled, as long as the Power Switch is also On.

NOTE: The Modbus register to program Digital Output 1 in static set point mode is 2000.

NOTE: In the Profile Create and Edit menus, Digital Output 1 is named **CONDITION**. Remember to set **CONDITION** to **On** in all programmed steps when the chamber is to be operational.

To Enable or Disable all chamber functions in static set point mode:

1. The F4 Temperature Controller must first be on the Main Page. Press the ▲ or ▼ key to position the Cursor next to the DigitalOut prompt.
Main Page _____
SP1 85.0°C ▲
SP2 85.0% ■
▶ DigitalOut _____ ▼
2. Press the ▶ key once. You will see Choose Event Output prompt in the lower display. Press the ▲ or ▼ key to position the Cursor next to Event Output1.
Choose Event Output_ _____
▶ Event Output1 _____
Event Output2 _____ ■
Event Output3 _____ ▼
3. Press the ▶ key once to select Event Output1. Then, press the ▲ or ▼ key to select On or Off.
Event Output1 _____
Off _____
▶ On _____
4. Press the ▶ key once to return to the Choose Event Output prompt.
5. Press the ◀ key once to return back to the Main Page. You will see a 1 in the DigitalOut line if Event1 is On.
Main Page _____
SP1 85.0°C ▲
SP2 85.0% ■
▶ DigitalOut1 _____ ▼

Event Outputs for Customer Use

The F4 Controller has digital outputs which can be configured as Event Outputs to turn remote devices on and off. There are four Event Outputs which are available for customer use. Event Output 1 is dedicated for System Enable. Event Output 2 is dedicated for Humidity Enable. Event Output 3 is dedicated for Purge. Event Output 8 is configured to control the refrigeration compressors. The Event Outputs 4 through 7 are available for customer use.

Event Assembly

The Event Assembly contains four solid state relays to control AC operated devices, such as power to a test sample. The solid state relays are rated for 24 to 240 VAC, 5.0 Amps.

Connecting to the Event Board

1. Unplug the chamber from the power source.
2. Remove the top cover.
3. Locate the Event Assembly and connect your wires to the desired solid state relay terminals.
4. The event outputs are just switches. You must provide power from an external source.
5. A 1/2-inch conduit hole is provided on the back panel to route your wires through. Use the appropriate wire/cable management fittings.

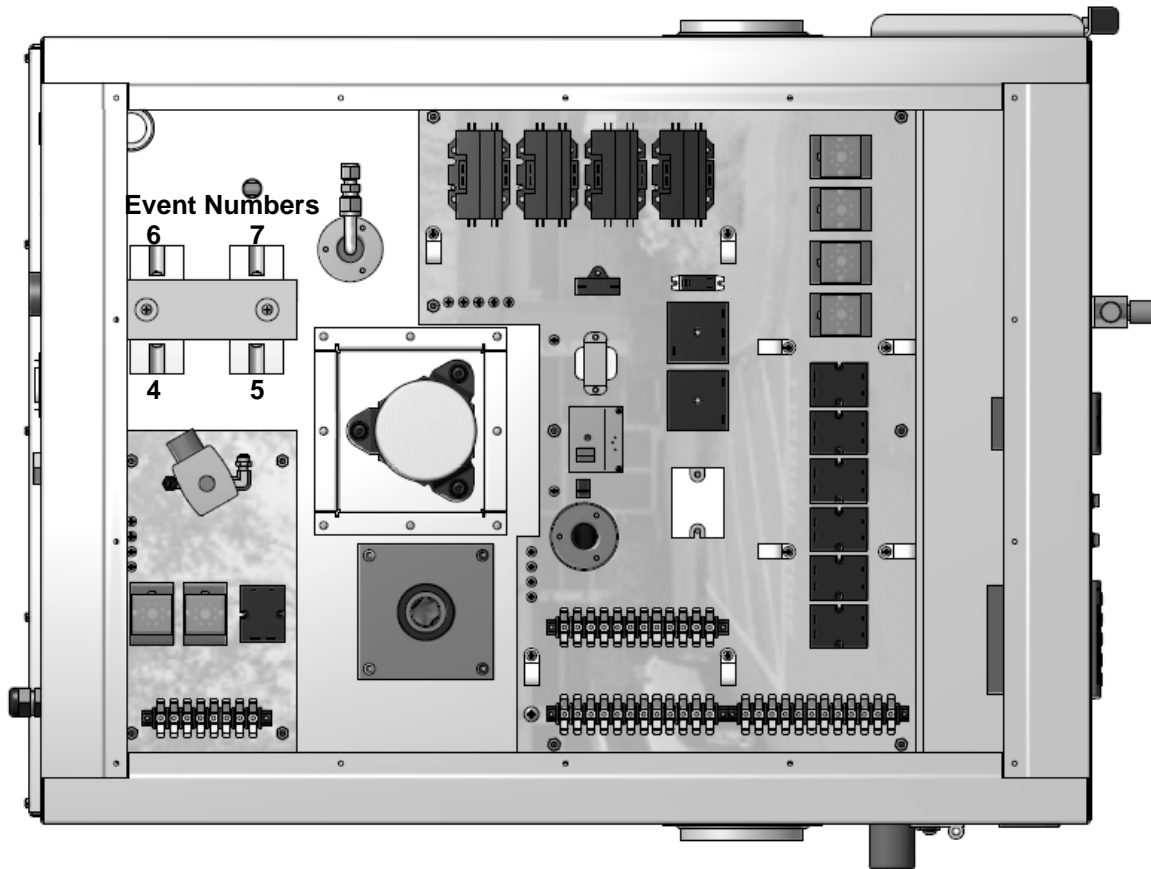

Figure 4.3 – Event Relay Location

Purge

GN₂ (gaseous nitrogen) Purge or optional Dry Air Purge can be used to reduce to possibility of condensation in the chamber at low temperatures, or to achieve humidity control below a 6°C dew-point condition.

⚠ CAUTION: Nitrogen cannot be detected by human senses. Nitrogen is non-toxic. However, if adequate ventilation is not provided, nitrogen will displace air. This can cause dizziness, unconsciousness or death without warning. The chamber must be located in a well-ventilated area. Do not open the chamber door with the GN₂ flowing.

GN₂ (Gaseous Nitrogen) Installation

Connect a supply of GN₂ with a maximum pressure of 100 psig to the 1/4-inch FPT fitting which is designated PURGE on the rear panel.

Dry Air Installation (TE-0017)

Connect the hose from the Dry Air system to the fitting which is designated PURGE on the rear panel. Connect a supply of compressed air to the 3/8-inch FPT shutoff valve of Dry Air system. This system requires a 5 cfm supply air flow rate at 100 psig (175 psig max).

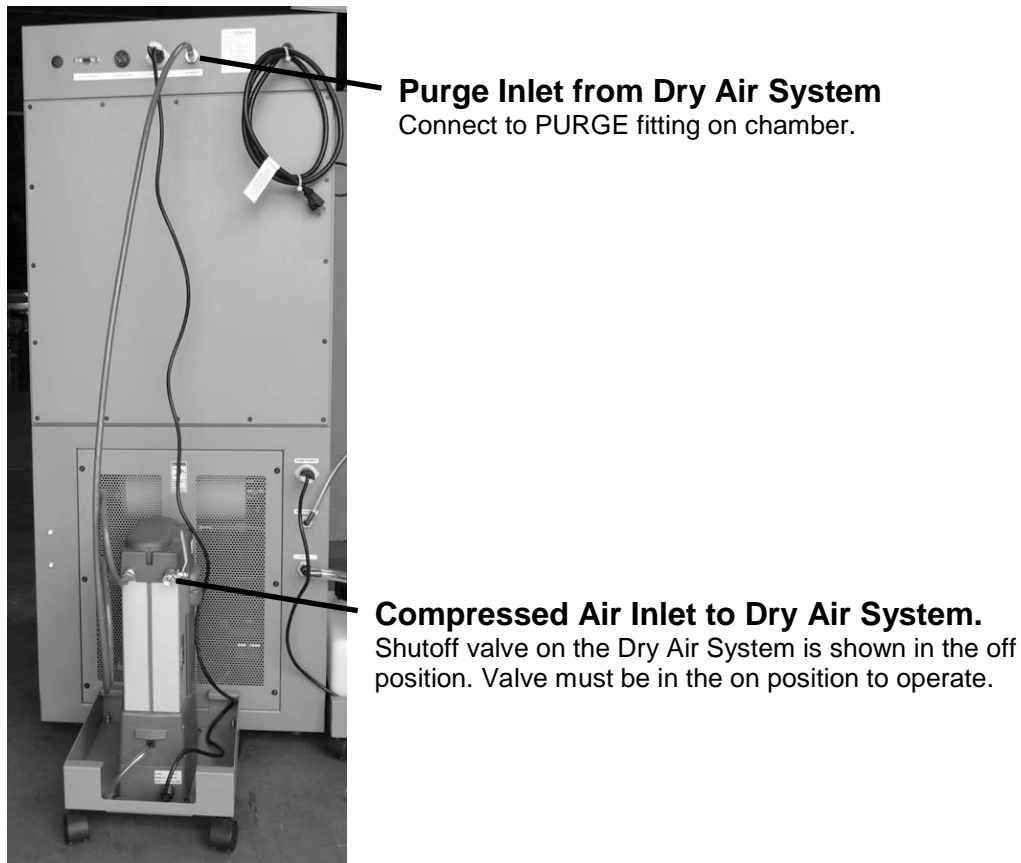

Figure 4.4 – Dry Air Purge System Installation

Purge Operation

The Purge mode is enabled through Event 3 (Digital Output 3) in the F4 Controller.

NOTE: The Modbus register to program Digital Output 3 in static set point mode is 2020.

NOTE: In the Profile Create and Edit menus, Digital Output 3 is named PURGE. Remember to set PURGE to On in all programmed steps when the you want to use the purge.

The Event Outputs are accessed from the DigitalOut prompt on the Main Page in static set point mode, and the DIGIT OUT prompt in the Profile programming mode.

For low humidity control

- Turn Event 2 (HUMIDITY) ON and Event 3 (PURGE) ON.
- Purge gas will feed when the F4 Controller cycles the dehumidification system. It will cycle on/off as the workspace humidity approaches and reaches the low humidity set point, or whenever dehumidification is necessary.

For low humidity control below +10°C

- Turn Event 2 (HUMIDITY) OFF and Event 3 (PURGE) ON.

Event 2 (HUMIDITY) must be OFF to achieve temperatures below +10°C. If Event 3 is ON, the Purge System will continue to provide controlled dehumidification even though the humidity system is disabled.

Adjusting the Purge Flow

A flowmeter is located on the front panel to adjust the flow of purge gas into the chamber. The flowmeter has a scale, calibrated in SCFM. The flow of purge gas should be adjusted to the minimum amount required to obtain the desired drying in the chamber for your particular conditions. A suggested starting setting is 2 SCFM.

Relief Vent

Excess pressure in the chamber workspace is vented through a pressure-relief check-valve, which is located on the top of the chamber.

Profile Programming

The Series F4 Controller can be programmed to store up to 256 steps into as many as 10 profiles. You do not need a computer to enter a profile – it can be easily done through the controller's front panel keys. A Profile is a set of instructions programmed as a sequence of steps. The controller handles the profile steps automatically, in sequence. As many as 40 different profiles and a total of 256 steps can be stored in non-volatile memory. The 256 steps are grouped by profile. So, one profile could have 256 steps; or 39 profiles could have 6 steps and one could have 22; or 32 profiles could have eight steps each. The maximum number of steps is 256, and the maximum number of profiles is 40.

Step Types

Use the five available step types – Autostart, Ramp Time, Soak, Jump and End – to create simple or complex profiles involving all inputs and outputs. The Series F4 prompts you to define each step's properties.

Autostart Step

The use of an Autostart step in a profile is optional. Autostart pauses a profile until the specified date or day, and time (of a 24-hour-clock). Define the Autostart by choosing:

- Day (of the week) or Date,
- Time

To invoke an Autostart step in a profile, you must activate the profile via the Profile Key and select the Autostart step.

Ramp Time Step

Ramp Time changes the set point to a new value in a chosen period of time. Define the Ramp Time step by choosing:

- *Wait for an event or process value
- Event outputs 1 through 7 to turn ON or OFF (For controlling the chamber functions or power to remote devices).
- Time (in hours, minutes and seconds)
- Temperature Set Point
- PID set (One of five sets of PID parameters for Ch1 and Ch2. Normally, just leave Ch1 at PID Set 1 and Ch2 at PID Set 6.)
- **Guaranteed Soak

Soak Step

Soak maintains the set point from the previous step for a chosen time in hours, minutes and seconds. Define the Soak step by choosing:

- *Wait for an event or process value
- Event outputs 1 through 7 to turn ON or OFF (For controlling the chamber functions or power to remote devices).
- Time
- PID set (One of five sets of PID parameters for Ch1 and Ch2. Normally, just leave Ch1 at PID Set 1 and Ch2 at PID Set 6.)
- **Guaranteed Soak

Jump Step

Jump initiates another step or profile. Define the Jump step by choosing:

- Profile to jump to;
- Step to jump to; and
- Number of Repeats

NOTE: If a power-out condition occurs during a profile and more than 20 jump steps are stored in the F4's Profile Program memory, the controller will terminate the profile and turn off all outputs if Continue, Hold or Terminate was selected as the Power Out action. If Profile Reset or Go to Idle Set Point was selected, the controller will take those actions. A pop-up message will warn of this when the 21st jump step is programmed

End Step

End terminates the profile in a chosen state. All profiles must have an End step. It cannot be deleted or changed to another step type. Define the End by choosing Hold, Control Off, All Off or Idle end state.

NOTE: TestEquity recommends having the end step type to be Hold or Idle. TestEquity does NOT recommend using an end step type of Control Off or All Off. This does not turn off the chamber fan. The chamber temperature can reach +55°C just from heat generated by the fan, and even higher if your test sample is energized. If you want to turn the chamber off at the end of a profile, see System Enable Function on page 4-7.

***Wait For step option**

The use of Wait For in a profile is optional. Ramp Time, Ramp Rate and Soak steps can be programmed to wait for a particular chamber temperature or event input condition. The wait conditions must be satisfied before the time clock and the step activity proceeds. Digital inputs must first be configured in the System Menu as Wait For Events, with the condition to be met also specified. Then, to wait for this digital input, you must specify On, meaning the condition as configured in the Setup Page, or Off, meaning the opposite of that condition. The digital inputs have been configured to Off by TestEquity, so this option will not show unless reconfigured.

****Guaranteed Soak step option**

The use of Guaranteed Soak in a profile is optional. The Guaranteed Soak step requires the chamber temperature to be at the set point temperature, within the Guaranteed Soak Band value, before the time clock and the step activity proceeds. The Guaranteed Soak Band is configured by TestEquity to 3.0°C for SP1 and 5.0%RH for SP2, and this can be changed in the System Menu.

How to Program a New Profile

<p>1. Go to the Profiles Page. Move the cursor down the Main Page to Go to Profiles, then press the ► key.</p>	<p>Main Page _____ ► Go to Profiles ▲ Go to Setup ■ Go to Factory ▼</p>
<p>2. Create a new Profile. The cursor will be on Create Profile. Press the ► key.</p>	<p>Main>Profile _____ ► Create Profile ■ Edit Profile ▼ Delete Profile ▼</p>
<p>3. Name the profile. You can name your profiles for easy reference if desired. Names can have up to 10 characters. You can also use one of the default profile names (ex. Profile1), and skip this step. To name a profile:</p> <ul style="list-style-type: none"> • Press ► to enter the name space and the first position. • Press the ▲ or ▼ to scroll through the alphabet and stop at the letter or number desired. • Press ► to move to the next position. • Continue until the name is complete, or until you move through the name space into the next screen. • Press ► to save the name of the profile. 	<p>Choose to Name: _____ No ► Yes</p> <p>Enter Profile Name: _ <u>PROFILE1</u> ▲ ▼ Adjusts Char ◀▶ Save Changes</p>
<p>4. Choose the step type. • There are five step types, each of which must be defined through different parameters. (See “Step Types,” earlier in this chapter.)</p>	<p>Choose Step1 Type: _____ Autostart ► Ramp Time ■ Soak ▼</p>
<p>5. Define each step type. • The Series F4 prompts you to define the parameters of each step type. (See “Step Types,” earlier in this chapter.)</p> <p>(Not all menu choices are shown in this example)</p>	<p>Choose to wait: _____ ► Step does not wait Step waits for...</p> <p>Choose HUMIDITY: _____ Off ► On</p> <p>Enter Ramp Time: _____ 00:00:01 (H:M:S) ▲ ▼ Adjusts Digit ◀▶ Save Changes</p> <p>Enter Ch1 SP: _____ 85.0 °C ▲ ▼ Adjusts Value ◀ Back ▶ Next</p>
<p>6. Choose the end-state. • All profiles end with an End step, which is preprogrammed into the new profile. (See “End Step,” earlier in this chapter.)</p>	<p>Choose End State: _____ Control Off ▲ All Off ■ ► Idle</p>
<p>7. Save your settings. • Press ◀ to exit the Profiles Page. • After exiting the Profiles Page, choose ▲ to save profile data.</p>	<p>Save profile data or restore values? ▼ Restore ▲ Save</p>

Programming Hints

- The first step in a program should be an initialization step of 1-second.
- The next to last step establishes a condition to end on. For example, you may want to end the program by holding at +23°C, so this step would be to go to +23°C.
- The final step of every profile is End. You cannot delete an End step or change it to another type, but you can insert new steps before it.
- Remember to set HUMIDITY to On in all programmed steps when the chamber is to be in the controlled humidity mode.
- TestEquity recommends having the end step type to be Hold or Idle. TestEquity does NOT recommend using an end step type of All Off or Control Off. This does not turn off the chamber fan. The chamber temperature can reach +55°C just from heat generated by the fan, and even higher if your test sample is energized. See Protecting an Energized Test Sample in Chapter 5 for important information regarding energized test samples.
- If you must turn off all chamber functions at the end of a profile, see System Enable Function in Chapter 4. If this function is used, the you must remember to set CONDITION to On in all programmed steps when the chamber is to be operational.

Profile Key

The  Profile key initiates the profile mode. You can also hold, resume or terminate a running profile with this key. The Profile Key functions only from the Main Page.

How to Start a Profile

To initiate the profile mode, press the  Profile key and answer the questions that follow.

<p>1. Press the Profile key to enter the Profile Control menu.</p> <ul style="list-style-type: none"> • The Profile Indicator will begin blinking. • Press the ▲ key for Yes. 	<p>Start a Profile?</p> <p>▼ No ▲ Yes</p>
<p>2. Select the desired stored profile.</p> <ul style="list-style-type: none"> • Press the ▲ or ▼ to scroll through the list of stored profiles. • Press ► to select the desired profile. 	<p>Start Profile: _____</p> <p>Profile1</p> <p>► Profile2 ▮</p> <p>Profile3 ▼</p>
<p>3. Select the desired step to start on.</p> <ul style="list-style-type: none"> • Press the ▲ or ▼ to scroll through the list of steps. Generally you would start on Step 1, but you can also start on any other step. • Press ► to select the desired start step and the profile will begin to run. The Profile Indicator will stay lit. 	<p>Start: _____</p> <p>► Step 1 Ramp Time ▮</p> <p>Step 2 Soak ▼</p> <p>Step 3 Ramp Time ▼</p>
<p>Main Page _____</p> <p>► Profile 2 Running ▮</p> <p>Step 1 ▮</p> <p>SP1 85.0°C ▼</p>	

While running a profile, the Main Page on the lower display will keep you informed about the progress of the profile. Use the ▲ or ▼ key to scroll through the list of running profile parameters. You cannot manually change any operating condition while the profile is running.

How to Hold/Resume a Running Profile

<p>1. To Hold a running profile, press the Profile key to enter the Profile Control menu.</p> <ul style="list-style-type: none"> • Then press ▲ or ▼ to make your choice for Hold. • Press ► to select Hold. • The Main Page will appear with a profile status of Holding. The Profile Indicator will be off. 	<pre>Hold Profile: _____ Don't Hold ► Hold Terminate Main Page _____ ► Profile 2 Holding Step 2 SP1 23.0°C ▼</pre>
<p>2. To Resume profile on hold, press the Profile key to enter the Resume Profile menu.</p> <ul style="list-style-type: none"> • Then press ▲ or ▼ to make your choice for Resume. • Press ► to select Resume. 	<pre>Resume Profile: _____ Continue Holding ► Resume Terminate</pre>

While a profile is on Hold, the current set point can be adjusted at the SP1 prompt on the Main Page. When a profile is resumed during a Ramp step, the controller uses the Static Set Point from the Main Page to calculate the rate of change needed to get to the set point at the end of the step. When a profile is resumed in a soak step, the new set point value will be used as the soak value for the time remaining in the step.

How to Terminate a Running/Holding Profile

<p>1. Press the Profile key while the profile is running to enter the Resume Control menu.</p> <ul style="list-style-type: none"> • Then press ▲ or ▼ to make your choice for Terminate. • Press ► to select Terminate. 	<pre>Hold Profile: _____ Don't Hold Hold ► Terminate</pre>
--	--

If you manually terminate a running profile, the profile ends with a set point of Off. This does not turn off the chamber fan. The chamber temperature can reach +55°C just from heat generated by the fan, and even higher if your test sample is energized. See Protecting an Energized Test Sample in Chapter 5 for important information regarding energized test samples.

How to Delete or Re-Name a Profile

<p>1. Go to the Profiles Page. Move the cursor down the Main Page to Go to Profiles, then press the ► key.</p>	<pre>Main Page _____ ► Go to Profiles Go to Setup Go to Factory</pre>
<p>2. Choose Delete or Re-Name.</p> <ul style="list-style-type: none"> • Press ▲ or ▼ to scroll through your choice. • Press ► to select your choice. • The controller will prompt you to select the profile you want to delete or re-name. 	<pre>Main>Profile _____ Edit Profile ► Delete Profile Re-Name Profile</pre>

How to Edit a Profile

<p>1. Go to the Profiles Page. Move the cursor down the Main Page to Go to Profiles, then press the ► key.</p>	<p>Main Page _____ ► Go to Profiles Go to Setup Go to Factory</p>
<p>2. Choose Edit Profile. • Press the ▼ key to choose on Edit Profile. • Then press the ► key.</p>	<p>Main>Profile _____ Create Profile ► Edit Profile Delete Profile</p>
<p>3. Select the desired stored profile to edit. • Press the ▲ or ▼ to scroll through the list of stored profiles. • Press ► to select the desired profile.</p>	<p>...Edit Profile: _____ Profile1 ► Profile2 Profile3</p>
<p>4. Choose how to edit the step. • Press the ▲ or ▼ to scroll through the list of step edit choices. • Press ► to select your choice.</p>	<p>Choose to: _____ Insert Step ► Edit Step Delete Step Done</p>
<p>5. To edit a step. • Press the ▲ or ▼ to scroll through the list of steps you want to edit. • Press ► to scroll through the step parameters and make any desired changes.</p>	<p>Edit Step: _____ ► Step 1 Ramp Time Step 2 Soak Step 3 Ramp Time</p>
<p>6. To insert a step. • Choose Edit Profile (see step 4 above) • Press the ▲ or ▼ to scroll through the number of the step that the new step will precede. • Press ► to enter the new step and follow the step parameter prompts.</p>	<p>Insert Before: _____ Step 1 Ramp Time ► Step 2 Soak Step 3 Ramp Time</p>
<p>7. To delete a step. • Choose Delete Step (see step 4 above) • Press the ▲ or ▼ to scroll through the number of the step you want to delete. • Press ► to delete the step.</p>	<p>Delete Step: _____ Step 1 Ramp Time ► Step 2 Soak Step 3 Ramp Time</p>
<p>8. Save your settings. • Press ◀ successively to exit the Profiles Page. • After exiting the Profiles Page, choose ▲ to save the new profile values, or ▼ to restore the old values.</p>	<p>Save profile data or restore values? ▼ Restore ▲ Save</p>

NOTE:

- Inserting or deleting a step will renumber all steps that follow.
- A Jump Step that jumps to an End Step cannot be deleted.
- An End Step cannot be deleted.
- Inserting a new ramp step usually requires inserting an associated soak step.
- Deleting a ramp step usually requires deleting the associated soak step.

Chapter 4 – F4 Temperature/Humidity Controller

Profile Examples

The following are examples of two typical temperature-only profiles (uncontrolled humidity). Note that Digit Out 1, 2, 3 are named **CONDITION**, **HUMIDITY**, and **PURGE** respectively.

-40°C to 85°C, uncontrolled humidity, no ramps, 30 minute soak time, 4 cycles. Ends with +23°C set point. Turns chamber off at the end of the profile.

Step Number	Step Type	Date Day, Time	Wait for	1	2	3	4	5	6	7	Ch1 H:M:S	Ch2 SP	SP	Ch1 PID Set	Ch2 Guar. Soak	Jump to Ch1	Ch2	End Profile	Step	Repeats	Idle SP Type	Ch1
1	Ramp Time	---	>	On	>	>	>	>	>	>	00:00:01	-40.0	>	1	6	No	No	---	---	---	---	---
2	Soak	---	>	On	>	>	>	>	>	>	00:30:00	85.0	>	1	6	Yes	No	---	---	---	---	---
3	Ramp Time	---	>	On	>	>	>	>	>	>	00:00:01	---	>	1	6	No	No	---	---	---	---	---
4	Soak	---	>	On	>	>	>	>	>	>	00:30:00	---	>	1	6	Yes	No	Name	1	3	---	---
5	Jump	---	>	On	>	>	>	>	>	>	---	---	>	1	6	Yes	No	---	---	---	---	---
6	Ramp Time	---	>	On	>	>	>	>	>	>	00:00:01	23.0	>	1	6	No	No	---	---	---	---	---
7	Ramp Time	---	>	Off	>	>	>	>	>	>	00:00:01	23.0	>	1	6	No	No	---	---	---	---	---
8	End	---	>	---	>	>	>	>	>	>	---	---	>	1	6	No	No	---	---	---	---	---
9	End	---	>	---	>	>	>	>	>	>	---	23.0	>	1	6	No	No	Name	2	99	---	---

- Step Description**
- Goes to -40°C as quickly as possible.
 - Will hold for 30 minutes. Time will not start until chamber reaches -37°C (within the 3° Guaranteed Soak Band*).
 - Goes to +85°C as quickly as possible.
 - Will hold for 30 minutes. Time will not start until chamber reaches +82°C (within the 3° Guaranteed Soak Band*).
 - Jumps back to step 1. Repeats this 3-times, for a total of 4-cycles.
 - Goes to +23°C as quickly as possible. Time will not start until chamber reaches +26°C (within the 3° Guaranteed Soak Band*).
 - Turns the chamber off.
 - End of program. Controller returns to a +23°C manual set point.
- NOTE: Conditioning Switch must be in the Event 1 position to have the profile turn the chamber off.

+50°C to 0°C, 2°C/minute ramp, uncontrolled humidity, 1-hour soak times, 100 cycles total, test sample turned ON/OFF depending on step, end with a +23°C set point.

Step Number	Step Type	Date Day, Time	Wait for	1	2	3	4	5	6	7	Ch1 H:M:S	Ch2 SP	SP	Ch1 PID Set	Ch2 Guar. Soak	Jump to Ch1	Ch2	End Profile	Step	Repeats	Idle SP Type	Ch1
1	Ramp Time	---	>	On	>	>	>	>	>	>	00:00:01	23.0	>	1	6	No	No	---	---	---	---	---
2	Ramp Time	---	>	On	>	>	>	>	>	>	00:13:30	50.0	>	1	6	No	No	---	---	---	---	---
3	Soak	---	>	On	>	>	>	>	>	>	01:00:00	---	>	1	6	No	No	---	---	---	---	---
4	Ramp Time	---	>	Off	>	>	>	>	>	>	00:25:00	0.0	>	1	6	No	No	---	---	---	---	---
5	Soak	---	>	Off	>	>	>	>	>	>	01:00:00	---	>	1	6	No	No	---	---	---	---	---
6	Ramp Time	---	>	On	>	>	>	>	>	>	00:25:00	50.0	>	1	6	No	No	---	---	---	---	---
7	Jump	---	>	---	>	>	>	>	>	>	---	---	>	1	6	No	No	Name	2	99	---	---
8	Ramp Time	---	>	---	>	>	>	>	>	>	00:13:30	23.0	>	1	6	No	No	---	---	---	---	---
9	End	---	>	---	>	>	>	>	>	>	---	---	>	1	6	No	No	---	---	---	---	---

Step Description

- Establishes an initialization step. Goes to +23°C as quickly as possible. Test sample is turned ON via Event 1.
- Goes to +50°C at a controlled rate of 2°C per minute (50-23=27/2=13.5 or 13 minutes and 30 seconds). Test sample is turned ON via Event 3.
- Will hold for 1 hour. Test sample remains ON via Event 4.
- Goes to 0°C at a controlled rate of 2°C per minute (50-0=50/2=25 or 25 minutes). Test sample is turned OFF via Event 3.
- Will hold for 1 hour. Test sample remains OFF via Event 4.
- Goes to 50°C at a controlled rate of 2°C per minute. Test sample is turned OFF via Event 4.
- Jumps back to step 3. Repeats this 99-times, for a total of 100-cycles.
- After all cycles are completed, establishes the condition to end on. Goes to +23°C at a controlled rate of 2°C per minute. Test sample is turned OFF via Event 4.
- End of program. Controller returns to a +23°C manual set point. Test sample remains OFF via Event 4.

Notes

- * Guaranteed Soak Band is set at the factory for 3.0°C. Can be changed in the System Menu.
- > Means no entry or selection is required. Just scroll through this prompt to the next prompt.
- Means prompt does not show for this step type.

Operations Page

The Operations Page provides access to menus for control tuning (PID) and controller alarms. TestEquity has configured the security to require a password for access to all parameters in the Operations Page. You must call TestEquity at 877-512-3457 or 805-480-0638 to obtain the password.

⚠ CAUTION: The Series F4 alarms are configured and dedicated for internal protection of the humidity system. Do NOT change their configuration under any circumstances. The independent EZ-Zone Limit Controller functions as the main protection device.

⚠ CAUTION: The Series F4 Controller PID values have been properly configured by TestEquity to match the chamber's system requirements and to perform optimally over a wide range of operating conditions. Improper modifications to these values can result in erratic performance and unreliable operation. Do not attempt to modify the PID values, unless you thoroughly understand what you are doing. Setup examples in the "Series F4 User's Manual" are NOT applicable to this chamber. If there is any doubt, please call TestEquity before proceeding. The correct values are documented in the "Series F4 Controller Setup Parameters" section of this manual.

⚠ CAUTION: The Autotune PID function is not appropriate for use in this chamber. Using this function will result in tuning values that will not work correctly.

Setup Page

The Setup Page provides access to menus for configuring the controller hardware. TestEquity has configured the security to require a password for access to the Setup Page. However, there will be times when entry into these menus is necessary. For example, you may need to gain access to Setup Page in order to change from °C to °F display, or to change the time or date. You must call TestEquity at 877-512-3457 or 805-480-0638 to obtain the password.

⚠ CAUTION: The Series F4 Controller setup values have been properly configured by TestEquity to match the chamber's system requirements and to perform optimally over a wide range of operating conditions. Improper modifications to these values can result in erratic performance and unreliable operation. Do not attempt to modify the setup values, unless you thoroughly understand what you are doing. Setup examples in the "Series F4 User's Manual" are NOT applicable to this chamber. If there is any doubt, please call TestEquity before proceeding. The correct values are documented in the "Series F4 Controller Setup Parameters" section of this manual.

Factory Page

The Factory Page provides access to menus for controller diagnostics and calibration. TestEquity has configured the security to require a password for access to the Setup Page. However, there will be times when entry into these menus is necessary. For example, you may need to gain access to Factory Page in order to perform a calibration, or to change the security password. You must call TestEquity at 877-512-3457 or 805-480-0638 to obtain the password.

⚠ CAUTION: NEVER select “Full Defaults” in the Factory/Test Menu. This will erase all the correct values which are documented in the “Series F4 Temperature Controller Setup Parameters” section of this manual.

Computer Interface

⚠ CAUTION: Every setting in the F4 Controller can be accessed via the computer interface. Improper modifications to configuration settings can result in erratic performance and unreliable operation.

RS-232C

The F4 Temperature Controller has an RS-232C interface. A DB-9 connector is located on the rear panel. It is wired to accommodate a null-modem cable. To communicate with the controller from a PC, you need to run software that uses the Modbus RTU protocol. Each controller function has a “register” number which can be read or written to (when applicable). These registers are listed Chapter Seven of the “Series F4 User’s Manual”. RS-232C Modbus programming resources and LabVIEW drivers can be downloaded from <http://www.testequity.com/static/11/>.

Common Modbus Registers

- Actual chamber temperature reading is register 100 (Input 1 Value).
- Actual chamber humidity reading is register 104 (Input 2 Value).
- Static temperature set point is register 300 (Set Point 1).
- Static humidity set point is register 319 (Set Point 2).
- Temperature set point during a profile is register 4122 (Set Point 1, Current Profile Status).
- Humidity set point during a profile is register 4123 (Set Point 2, Current Profile Status).
- Decimal points are implied. For example, 1005 is actually 100.5 and -230 is -23.0.

GPIB (optional)

The optional GPIB interface consists of an internal board which converts the F4 controller’s serial interface to GPIB. Chambers with a GPIB interface have a GPIB connector in place of the RS-232C connector. GPIB programming resources and LabVIEW drivers can be downloaded from <http://www.testequity.com/static/10/>.

Ethernet (optional)

The optional Ethernet interface, model TE-1055, consists of an external converter box that connects to the chamber’s RS-232C interface.

Chapter 5 - Limit Controller

Introduction

The EZ-Zone Limit Controller is a protection device. It turns the chamber OFF if the workspace temperature exceeds either a high temperature or low temperature limit. You can set these limits to correspond to the maximum and minimum temperature that your test sample can safely withstand. This provides protection against someone setting the F4 Controller to a temperature that is unsafe for the test sample. It also provides protection in the unlikely event of a chamber system component failure. The Limit Controller has its own temperature sensor (thermocouple) and functions completely independent of the F4 Controller.

This section provides a brief overview on how to operate the Limit Controller. For more detailed instructions, see the “EZ-Zone User’s Manual”.

⚠ CAUTION: The “EZ-Zone User’s Manual” is a general manual and is written by the manufacturer, Watlow, for a wide variety of applications and configurations. Not all features or functions are applicable. Only the capabilities of a model PM6L1AJ-AAAABAA are applicable.

⚠ CAUTION: The EZ-Zone Limit Controller has been properly configured by TestEquity to match the chamber’s system requirements. Improper modifications to these setup values can result in unreliable and unsafe operation. Do not attempt to modify the setup values, unless you thoroughly understand what you are doing. The correct values are documented in the “EZ-Zone Limit Controller Setup Parameters” section of this manual.

⚠ CAUTION: Always verify that the Limit Controller’s high and low limits are set to temperatures that are appropriate for your test sample.

⚠ CAUTION: If your test sample is energized, it may be capable of raising the workspace temperature beyond safe limits. This could occur if your test sample exceeds the live load rating of the chamber or if the chamber’s refrigeration system fails. This chamber has a set of contacts that can be used to remove power to your test sample if the Limit Controller’s temperature limits are exceeded.

Limit Controller Keys and Displays

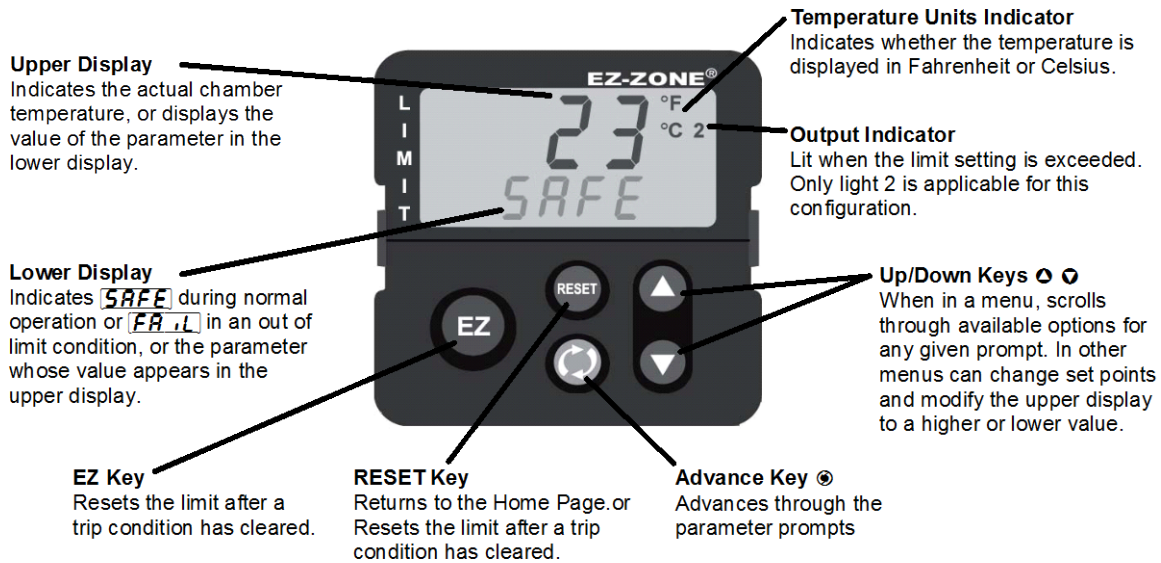

Figure 5.1 – Limit Controller Keys and Displays

How to Set the High and Low Temperature Safety Limits

1. Press the **⊙** key once to get the **LLS** prompt in the lower display. This is the Low Limit Set Point prompt.
2. Press the **▲** or **▼** key to enter the desired Low Limit Set Point in the upper display. Make sure it is lower than your actual chamber temperature set point, and at least below room temperature to prevent nuisance tripping.
3. Press the **⊙** key once again to get the **LhS** prompt in the lower display. This is the High Limit Set Point prompt.
4. Press the **▲** or **▼** key to enter the desired High Limit Set Point in the upper display. Make sure it is higher than your actual chamber temperature set point to prevent nuisance tripping.
5. Press the **RESET** Key to return to the Home Page.
6. The upper display will show the actual chamber temperature while the lower display will show **SAFE** as long as the limits are not exceeded.

Resetting an Out of Limit Condition

If the limit is exceeded, the Limit Controller will flash **L h I** (high limit) or **L l I** (low limit) in the upper display and **ALLO** in the lower display, alternating with the actual chamber temperature in the upper display and **FAIL** in the lower display. It will also shut down all chamber functions. The Limit Controller cannot be reset until the temperature returns to within the limit set points. Then, you must press the **RESET** or **EZ** Key to resume normal operation.

Silencing the Audible Alarm

Turning off the Conditioning switch on the chamber front panel lets you temporarily turn off the Audible Alarm, even though the High or Low Limit condition may still exist.

Protecting an Energized Test Sample

If your test sample is energized, it may be capable of raising the workspace temperature beyond safe limits. This could occur if your test sample exceeds the live load rating of the chamber or if the chamber’s refrigeration system fails.

This chamber has a set of safety contacts that can be used to remove power to your test sample if the Limit Controller’s temperature limits are exceeded.

The safety contacts are rated as follows:

Resistive: 10 A, 250 VAC or 10 A, 28 VDC. Inductive: 7 A, 250 VAC

To access the safety contacts:

1. Unplug the chamber from the power source.
2. Remove the top cover.
3. Locate the Terminal Strip on the electrical sub panel as indicated below. Connections to the safety contacts are at terminals A1 and A2.

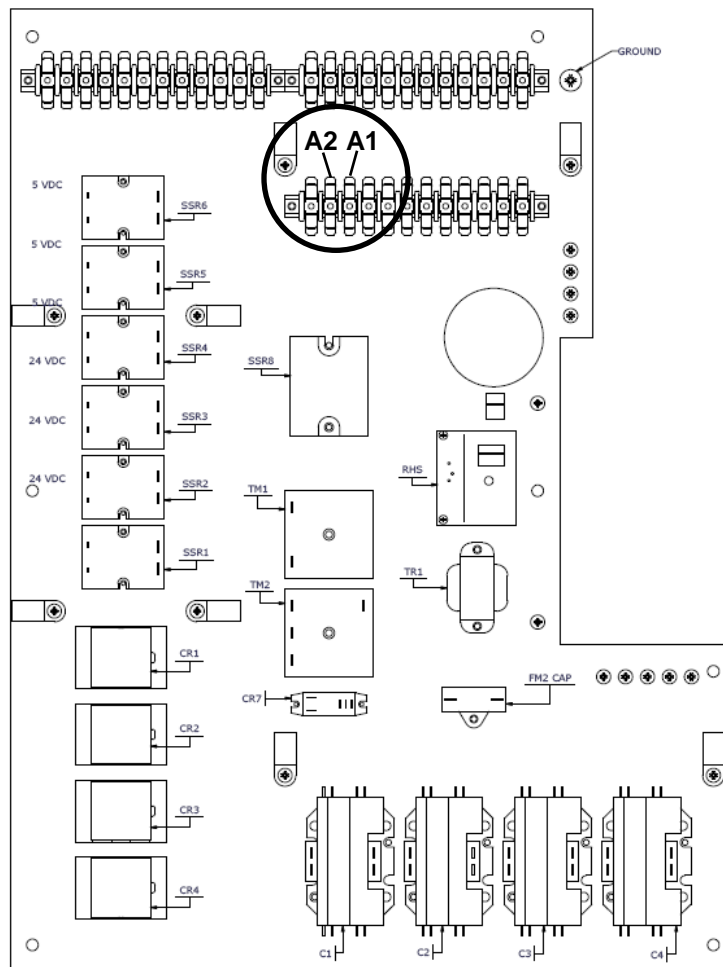

Figure 5-2 – Location of Safety Contact Connections on the Electrical Sub Panel

Chapter 6 – Frequently Asked Questions

I need to send the chamber outside North America. Will it work with their power?

Outside North America, most countries have 50 Hz. Nominal voltages in are typically 220 V to 240 V. You CANNOT simply step the voltage down to 120 V because the compressors have a 50 Hz rating of 100 V nominal (95 V min. to 110 V max.).

Why does my chamber heat or cool slower than the published specifications?

Performance is significantly affected by the characteristics of your test sample. Factors include size, weight, material, shape, and power dissipation if energized. The test sample should be placed in the chamber in a manner that allows for air circulation. You should not place the test sample directly on the chamber floor. It should be placed on the shelf. Multiple test samples should be distributed throughout the chamber to ensure even airflow and minimize temperature gradients. If necessary, additional shelves should be used to evenly distribute the load. You can determine if the chamber is operating properly by following the procedure in “How to verify the chamber performance”.

How can I modify the chamber to cool faster?

Unfortunately, there is little you can do to improve upon the designed-in performance. TestEquity does NOT recommend using CO₂ or LN₂ in this chamber to achieve faster cooling due to reliability and safety considerations, so it is NOT an available option. Modifying the chamber to add CO₂ or LN₂ will void the warranty.

Why is there water/ice/snow in the chamber?

Any time the ambient air is subjected to temperatures below the dew point, moisture will condense out of the air. The effect is ice or frost during low temperature operation. When the chamber is heated above 0°C, the ice or frost will turn into water. To avoid moisture condensation, make sure the port plugs are inserted at all times. Also, avoid opening the chamber door while the chamber is operating at temperatures below room ambient. When a low temperature test is completed, warm the chamber to at least room ambient before opening the chamber door and before removing your test sample.

My test specification requires convection heat only. Can I turn the circulator motor off?

NO! This will damage the heating and refrigeration systems and void the warranty. You need a “gravity convection oven” for that kind of test.

How accurate is the chamber?

That's a loaded question! There is no "chamber accuracy" specification as such. The answer requires an understanding of several performance parameters.

Control Tolerance – The F4 Controller uses a thermocouple control sensor, which is located in the discharge airflow. Control tolerance is a measure of how much the temperature varies after stabilization at the control sensor. It is a measure of the relative variations, NOT the absolute accuracy of the readout. The control tolerance specification for this chamber is $\pm 0.5^{\circ}\text{C}$, or a total of 1°C . For example, the temperature set point may be -25.0°C . The actual temperature varies between -25.4°C and -24.5°C . This corresponds to -0.4°C and $+0.5^{\circ}\text{C}$ or a total of 0.9°C of RELATIVE variations. These specifications are for an empty chamber. The addition of a test sample may effect the control variations. In some instances, the test sample will reduce these variations.

Uniformity – Also known as Gradients. This is a measure of variations in temperature at different locations throughout the chamber interior, at the same time, after stabilization. The uniformity specification for this chamber is $\pm 0.5^{\circ}\text{C}$ or a total of 1°C , when measured at least 2" away from the chamber interior walls. These specifications are for an empty chamber. The addition of a test sample may affect the temperature uniformity. For example, an energized test sample will produce a higher temperature near the sample.

Controller Accuracy – This is the ability of the F4 Controller to accurately display a temperature measurement when compared to a standard. The controller display accuracy is $\pm 1.66^{\circ}\text{C}$. However, the total measurement accuracy in the chamber includes the thermocouple sensor wire accuracy. Thermocouple wire accuracy is $\pm 1^{\circ}\text{C}$ or 0.75% of reading, whichever is greater. Therefore, total system accuracy over the chamber's operating range can be as much as $\pm 2.66^{\circ}\text{C}$, although the typical accuracy is often better than $\pm 1.0^{\circ}\text{C}$.

Can I tilt the chamber to move it?

You should be able to tilt the chamber 45 degrees to move it. After tilting it and moving it into place, perform the steps as outlined in "How to inspect the refrigeration machinery compartment" and "How to check the refrigerant charge" before placing the chamber back into service to make sure that no damage has occurred.

I'm not going to use the chamber for a while. Is there anything I should do to prepare it for storage?

Perform ALL the steps in the Preventive Maintenance Schedule before placing the chamber into storage. This will ensure that the chamber will be ready to operate when it is taken out of storage. If the chamber has a problem and is still under warranty, these problems should be resolved before being placed into storage, since the warranty period starts from the date of shipment. The chamber should be stored in a conditioned environment. Do not store it outside or where it will be subjected to dirt or excessive moisture.

I haven't used the chamber for a while. Is there anything I should do to prepare it for operation?

Perform ALL the steps in the Preventive Maintenance Schedule before placing the chamber back into service. This will ensure that nothing has been damaged and that a leak has not developed.

Chapter 6 – Frequently Asked Questions

Can the person who services our air conditioning also service the chamber?

Probably not. Most air conditioning mechanics are not familiar with low-temperature cascade refrigeration systems. While this chamber is relatively easy to maintain and repair, most air conditioning mechanics do not have the necessary refrigerants and may not be familiar with the microprocessor-based controls. This chamber should only be serviced by a qualified mechanic that is familiar with low-temperature cascade refrigeration systems. Call TestEquity to recommend one in your area, or to check if the one you would like to use is qualified.

Can/Should I put a filter in front of the condenser air inlet?

No, TestEquity does not recommend this. Just follow the maintenance procedures and clean the condenser fins periodically.

How often should I charge the refrigeration system?

This chamber uses a closed-loop refrigeration system. Just like your refrigerator at home, it does not need periodic charging. If the charge is low, this means that there is a leak. Leaks should be repaired before recharging.

What kind of Freon does the chamber use?

The word Freon[®] is a DuPont registered trade name for their CFC-based refrigerants and is incorrectly used as a generic term for refrigerants. TestEquity chambers do not use CFC-based refrigerants. The high-stage system uses R-404A, which is also known as DuPont Suva[®] HP62. The low-stage system uses R-508B, which is also known as DuPont Suva[®] 95.

Chapter 7 – Specifications

Model 123H Chamber Specifications

Temperature Range	-68°C to +175°C
Control Tolerance	±0.5°C (Measured at the control sensor after stabilization)
Uniformity	±0.5°C (Variations throughout the chamber after stabilization)

Standard Humidity Range 10% to 95%, in the temperature range of 10°C to 65°C limited by a 6°C dewpoint; 90% over 65°C up to 85°C. See chart on page 4-6.

Control Tolerance ±3%RH (Measured at the control sensor after stabilization)

Live Load Capacity @	+23°C	0°C	-40°C	-55°C	-65°C
	500 W	400 W	225 W	175 W	100 W

(Live load capacity is for non-humidity mode)

Cool Down Transition Time*		End Temp				
Start Temp to →	+23°C	0°C	-40°C	-55°C	-65°C	-68°C
+23°C	----	6 min	31 min	51 min	68 min	ultimate
+50°C	7 min	16 min	44 min	62 min	82 min	ultimate
+85°C	18 min	28 min	54 min	82 min	101 min	ultimate
+150°C	43 min	54 min	87 min	108 min	129 min	ultimate

Heat Up Transition Time*		End Temp				
Start Temp to →	+23°C	+50°C	+85°C	+125°C	+150°C	+175°C
+23°C	-----	2 min	12 min	24 min	33 min	ultimate
0°C	3 min	9 min	18 min	32 min	41 min	ultimate
-40°C	9 min	16 min	25 min	39 min	48 min	ultimate
-55°C	14 min	18 min	31 min	44 min	53 min	ultimate
-65°C	15 min	21 min	32 min	45 min	54 min	ultimate

***Note:** Transition times are measured after a 2-hour soak at the start temperature with an empty chamber.

Input Power 120 V nominal (110 to 126 VAC), 60 Hz, 1 PH
Max Current Draw 18 A, Recommended Minimum Service 20 A (dedicated line)

Workspace Dimensions 18" W x 16.5" H x 13.5" D (2.3 cubic feet)
Outside Dimensions 26" W x 63" H x 36.5" D (nominal). Vent tube adds 3" to height.
Min. Installed Clearance 6" from the left and right side, 12" from the rear
Access Ports 4" Port on left and right side (two total), Supplied with foam plugs
Sound Level 62 dBA (A-weighted, measured 36" from the front)
Weight 750 pounds

NOTE: Performance is typical and based on operation at 23°C (73°F) ambient and nominal input voltage. Designed for use in a normal conditioned laboratory. Operation at higher ambient temperatures may result in decreased cooling performance. Additional ports and shelves will also affect performance. Operation above 30°C (85°F) or below 16°C (60°F) ambient is not recommended.

F4 Controller Specifications

Specifications as configured for the TestEquity 123H Chamber

Accuracy & Sensor Conformity*	$\pm 1.55^{\circ}\text{C}$ (above -50°C) $\pm 1.66^{\circ}\text{C}$ (below -50°C)
Stability	$\pm 0.1^{\circ}\text{C}/^{\circ}\text{C}$ rise in ambient
Digital Inputs	(Four) Contact closure or dc voltage, 10 k Ω impedance
Retransmit Outputs (Optional)	(Two) User-selectable ranges: 0 to 10 VDC, 0 to 5 VDC, 1 to 5 VDC 0 to 20 mA, 4 to 20 mA
Alarm Outputs	(Two) Electromechanical relay; Form C, 2 A @ 20 VDC or 240 VAC max.
Digital Outputs	(4 available for customer use) Open collector output OFF: 42 VDC @ 10 μA max. ON: 0.2 VDC @ 50 mA sink max. Internal supply: 5 VDC @ 80 mA
Communications	EIA-232 and EIA-485 serial communications with Modbus™ RTU protocol
Safety & Agency Approvals	UL/c-UL 916-listed, File #E185611 CE to EN61010 NEMA 4X and IP65 CE EMC to EN50082-2 CE EMC to EN55011
Displays	Process: 5, seven-segment red LED. Interface Display: 4-line high-definition green LCD; Selectable $^{\circ}\text{C}$ or $^{\circ}\text{F}$
Data Retention	Retention upon power failure via nonvolatile memory (Seven years for battery-backed RAM)

***Note:** Total system accuracy in the chamber includes thermocouple wire accuracy. Thermocouple wire accuracy is $\pm 1^{\circ}\text{C}$ or 0.75% of reading, whichever is greater. Therefore, total system accuracy over the chamber's operating range can be as much as $\pm 2.66^{\circ}\text{C}$, although the typical accuracy is often better than $\pm 1.0^{\circ}\text{C}$.

Chapter 8 – Maintenance

⚠ **WARNING:** Maintenance must be performed by properly trained personnel only.

Preventive Maintenance Intervals

Daily or As Needed

- Clean chamber interior and exterior.
- Listen for abnormal noise or vibration.
- Inspect the demineralizer cartridge (if provided).

Every 3 Months

- Inspect the door seal.
- Inspect the refrigeration machinery compartment.
- Verify the chamber performance.

Every 6 Months

- Inspect the electrical compartment.
- Clean the condenser.
- Drain the humidity system.

Every 12 Months

- Verify the calibration.

Maintenance Procedures

How to Clean the Chamber Interior and Exterior

- Wipe or vacuum out all debris.
- Clean surfaces with a damp cloth, mild detergent, or stainless-steel cleaner. Avoid cleaners that are abrasive or leave a residue. Do NOT use steel wool.
- If you clean the interior with something other than water, you may want to operate the chamber at high temperature (approximately +125°C) after cleaning. This helps to “bake out” any residue. Remove the port plugs to permit the residual vapors to escape.
- Clean the silicone door gaskets with a damp cloth or mild detergent.
- Clean the exterior painted surfaces with a damp cloth or mild detergent. If you are using a detergent, test a small inconspicuous area to make sure it does not damage the finish.

How to Listen for Abnormal Noise or Vibration

You should become familiar with normal operating noises. Being able to recognize changes from normal operating noises can be a valuable way to identify problems and prevent further damage. Examples of noises to be aware of include:

- Circulator motor and fan noises (with compressors off).
- Compressor start-up and running noises, sequential starting of compressors.
- Condenser fan noises.
- Relay and valve cycling noises when cool light is cycling.

How to Inspect the Door Seal

The door has two silicone gaskets to minimize thermal losses and moisture migration.

- Inspect the gaskets for dirt and tears.
- Repair minor tears with a high quality RTV silicone such as GE RTV167.
- Check the integrity of the door seal by closing the door on a sheet of paper. With the door closed, slowly pull the paper. You should feel the resistance getting lighter as the paper goes past the inner gasket. Repeat this all around the door at several places.
- If the seal is not tight, adjust the door latch. The catch bracket that is mounted to the chamber has slotted holes to permit adjustment.
- If the seal is still loose on the hinge side, adjust the door hinge. The hinges have slotted holes to permit adjustment.

How to Inspect the Refrigeration Machinery Compartment

⚠ **WARNING:** Wear safety goggles when inspecting the machinery compartment to protect against a refrigerant line which could break.

1. Unplug the chamber from the power source.
2. Remove the side and rear panels.
3. Inspect for signs of water leaks.
4. Inspect for signs of refrigeration tubing abrasion.
5. Inspect for oil around refrigeration valves, fittings and joints. This may be a sign of leaks.
6. Inspect for loose hardware and tighten as required.
7. Inspect for signs of insect or rodent infestation. Yes, it does happen!

How to Verify the Performance (Non-controlled humidity mode)

These tests verify the performance of the heating, cascade refrigeration mode, electrical controls, F4 Controller, and air circulation systems. The chamber should meet all published performance specifications for non-controlled humidity conditions if all of these tests are successfully passed. These tests assume that the F4 Controller's setup and tuning values have not been changed from the values as shipped from TestEquity. Also, the EZ-Zone Limit Controller high limit must be set to over +85°C (+88°C would be fine), and the low limit set to -75°C. If the chamber fails any of these tests, it should be removed from service to prevent further damage until the cause of the problem is determined and resolved.

1. The chamber interior should be empty and at ambient temperature, approximately +23°C.
2. Turn ONLY the Power Switch ON. Event 2 (Digital Output 2) must be Off.
3. Set the F4 Controller Set Point 1 to +85°C. Then, turn the Conditioning Switch ON.
4. The Heat Light should be ON continuously and the Cool and Humidity lights should be OFF.
5. The chamber should heat up to about +80°C and begin controlling (HEAT Light cycles ON/OFF) within approximately 12 minutes.
6. The chamber temperature should slowly increase and stabilize to +85°C. It should NOT overshoot beyond +85°C by more than a few tenths of a degree, and the compressors should NOT need to turn ON in order to maintain +85°C.
7. After stabilization, the chamber temperature should vary no more than $\pm 0.2^{\circ}\text{C}$, or a total of 0.4°C.
8. Let the chamber stay at +85°C for two hours.
9. After two hours at +85°C, set the F4 Controller Set Point 1 to -65°C.
10. The high-stage compressor should turn ON within a few seconds. Then, the low-stage compressor should turn ON within approximately 30 seconds, the Cool Light should be ON continuously and the Heat Light should be OFF.
11. The chamber should cool down to about -60°C and begin controlling (Cool Light cycles ON/OFF) within 1 hour and 40 minutes (100 minutes).
12. The chamber temperature should slowly decrease and stabilize to -65°C. It should NOT undershoot beyond -65°C by more than a few tenths of a degree, and the compressors should NOT need to turn OFF in order to maintain -65°C.
13. After stabilization, the chamber temperature should vary no more than $\pm 0.5^{\circ}\text{C}$, or a total of 1°C.
14. Set the F4 Controller Set Point 1 to +23°C. The chamber should begin to heat up. The compressors should turn off within approximately 1 minute.
15. This concludes the chamber performance verification tests.
16. Let the chamber heat up to +23°C before turning the Conditioning Switch OFF.

How to Verify the Performance (Controlled humidity mode)

These tests verify the performance of the heating, single-stage refrigeration mode, humidification, electrical controls, F4 Controller, and air circulation systems. The chamber should meet all published performance specifications for controlled humidity conditions if all of these tests are successfully passed. These tests assume that the F4 Controller's setup and tuning values have not been changed from the values as shipped from TestEquity. Also, the Limit Controller high limit must be set to over +85°C (+88°C would be fine). If the chamber fails any of these tests, it should be removed from service to prevent further damage until the cause of the problem is determined and resolved.

1. The chamber interior should be empty and at ambient temperature, approximately +23°C. Water Inlet must be connected to a source of filtered water or the optional water recirculation system.
2. Set the F4 Controller Set Point 1 to 85.0°C, and Set Point 2 to 85.0% RH. Event 2 (Digital Output 2) must be ON. Turn the Conditioning Switch ON.
3. The Heat Light and Humidity Mode Light should be ON continuously and the Cool light should be OFF. The Humidity Light should be ON continuously only after the humidifier fills up with water.
4. The chamber should heat up to about 80°C and begin controlling (Heat Light cycles ON/OFF) within 7 minutes.
5. The chamber temperature should slowly increase and stabilize to 85°C. It should NOT overshoot beyond 85°C by more than 1.0°C, and the compressor should NOT need to turn ON at this point in order to maintain 85°C.
6. The chamber humidity should begin to increase within approximately 5-10 minutes after the Humidity Light turns on. Then, the humidity should increase to 75% RH and the begin controlling (Humidity Light cycles ON/OFF)
7. After stabilization, the chamber temperature should be 85.0°C, $\pm 0.5^\circ\text{C}$. The humidity should be 85.0%RH, $\pm 0.5\%$ on a short-term basis, with no more than a -3% RH dip on an occasional basis.
8. Next, change Set Point 1 to 50.0°C. Leave Set Point 2 at 85.0% RH
9. The high-stage compressor should turn ON (if it was not already ON), the Cool Light should be ON continuously and the Heat Light should be OFF. The humidity will drop at this point.
10. The chamber should cool down to about 55°C and begin controlling (Cool Light cycles ON/OFF) within a short time.
11. The chamber temperature should decrease and stabilize to 50°C. It should NOT undershoot 50°C by more than 2°C, and the compressors should NOT need to turn OFF in order to maintain 50°C. After stabilization, the chamber temperature should be 50.0°C $\pm 0.5^\circ\text{C}$, or a total of 1°C. It may take approximately 45 minutes to stabilize at 85.0%, $\pm 2.0\%$ RH.
12. Next, change Set Point 2 to 50.0%RH. Leave Set Point 1 at 50.0°C.
13. The Humidity light will be OFF. The chamber humidity should go down to about 60%RH fairly quickly. It may take approximately 15 additional minutes to stabilize at 50.0%, $\pm 2.0\%$ RH.
14. This concludes the controlled-humidity chamber performance verification tests.

How to Inspect the Electrical Compartment

1. Disconnect the chamber from the power source.
2. Remove the top cover.
3. Check for loose components, loose wires, burned insulation near terminals, and burned or excessively pitted contacts on contactors.

How to Clean the Condenser

1. Disconnect the chamber from the power source.
2. Remove the lower front panel.
3. Clean the condenser and desuperheater fins with a vacuum cleaner.

NOTE: You may need to clean the condenser more frequently if the chamber is in a dusty environment. You may be able to clean the condenser less frequently if the chamber is in a very clean environment.

How to Drain the Humidity System

1. Wait at least 2 hours after running a humidity test before draining the system.
2. Disconnect the chamber from the power source.
3. Remove the lower rear panel.
4. Open the Drain Valve by turning its handle 90 degrees counter-clockwise (as if you are facing the front of the valve handle). Water will come out of the Drain fitting on the back of the chamber.
5. After the system is drained, close the Drain Valve by turning its handle 90 degrees clockwise (as if you are facing the front of the valve handle).



Figure 8-1 – Humidity Drain Valve (shown in the closed, or normal operating position)

How to Verify the Temperature Calibration

TestEquity recommends verifying the temperature calibration before attempting to actually perform a calibration. The state-of-the-art instrumentation used in TestEquity chambers is of the highest quality and seldom goes out of calibration. If you try to calibrate the instrumentation before determining that calibration is necessary, you may make it worse if done incorrectly.

Variations in temperature throughout the chamber interior is NOT a measurement of accuracy. These variations, called “gradients”, are a function of the physical design of the chamber and its airflow, the characteristics of the test sample, and how it is oriented in the chamber. You cannot “calibrate” to improve gradients. The correct way to adjust what the F4 Controller “displays” compared to what is measured at some point other than the controller’s sensor, is with the “Calibration Offset” parameter. See page 6.2 of the “Series F4 User’s Manual” for details. Calibration verification should be performed with the Calibration Offset set to 0.0 (zero).

The F4 Controller accuracy is specified $\pm 1.55^{\circ}\text{C}$ (above -50°C) and $\pm 1.66^{\circ}\text{C}$ (below -50°C). Total system accuracy in the chamber includes the controller plus the thermocouple wire accuracy of $\pm 1.0^{\circ}\text{C}$. Total system accuracy over the chamber’s operating range is can be as much as $\pm 2.66^{\circ}\text{C}$, although it is typically better than $\pm 1.0^{\circ}\text{C}$.

The easiest way to verify the instrumentation accuracy is with an independent calibrated temperature sensor and display. Place the sensor near the chamber’s sensors, which are located towards the right side of the conditioner fan grille. If the readings agree within the specified limits above, then no calibration adjustments are necessary.

If calibration of the F4 Controller is necessary, refer to page 9.2 of the “Series F4 User’s Manual” and follow the instructions for “Thermocouple Input Procedure” for Input 1.

How to Verify the Humidity Calibration

TestEquity recommends verifying the humidity calibration before attempting to actually perform a calibration. If you try to calibrate the instrumentation before determining that calibration is necessary, you may make it worse if done incorrectly.

A Vaisala HMM100 capacitive-type sensor is used to measure humidity. The HMM100 output is configured for 0-100%RH = 0-20 mA. The HMM100 sensor specifications are:

Sensor accuracy at -20°C to $+40^{\circ}\text{C}^*$	Sensor accuracy at -40°C to -20°C , $+40^{\circ}\text{C}$ to $+175^{\circ}\text{C}^*$
$\pm 2\% \text{RH}$ (0 to 90 %RH)	$\pm 2.5\% \text{RH}$ (0 to 90 %RH)
$\pm 3\% \text{RH}$ (90 to 100%RH)	$\pm 3.5\% \text{RH}$ (90 to 100%RH)
*Note: Chamber controlled humidity range is 10°C to 85°C	

The easiest way to verify the instrumentation accuracy is with an independent calibrated humidity sensor and display. Place the sensor near the chamber’s humidity sensor, which is located towards the right side of the conditioner fan grille. If the readings on the F4 Controller agree within the specified limits above, then no calibration adjustments are necessary.

Humidity Sensor Calibration and Maintenance

Humidity sensor calibration can be checked with Vaisala HMK15 Humidity Calibrator which uses saturated salt solutions. The Vaisala HM70 Handheld Humidity/Temperature Meter is also convenient for checking the reading of the HMM100 against a calibrated measuring device. These items are available from Vaisala Inc. (www.vaisala.com). The Vaisala HMM100 sensor is calibrated per the procedure in the Vaisala HMM100 User's Guide, which can be downloaded from www.testequity.com/static/163/.

The humidity sensor element (Vaisala HUMIKAP 180R) is replaceable. The end of the sensor probe has a stainless steel sintered filter (Vaisala HM47280SP), which can be removed by unscrewing it. Handle the sensor by its outer plastic support. **DO NOT TOUCH THE SENSOR PLATE.** The sensor and sintered filter can be cleaned with distilled water. Do not use any mechanical methods. If you are unable to calibrate the sensor, first try cleaning the sensor element and filter. If this does not help, then replace the sensor.

How to Verify the F4 Controller's Input 2 (Humidity Input) Calibration

The above assumes that Input 2 of the F4 Controller is in calibration. Input 2 is configured for 0 to 20 mA = 0 to 100% RH.

1. Disconnect the chamber from the power source. Remove the top cover.
2. Remove the existing sensor wires on terminals 54 and 58 of the F4 Controller.
3. Connect a 0 to 20 mA precision current source, + to terminal 54 and – to terminal 58.
4. Set the precision source to 10.0 mA.
5. Reconnect the chamber to the power source.
6. Turn the Power Switch ON and leave the Conditioning Switch OFF.
7. Observe that the Input 2 prompt in the lower display indicates between 49.0% and 51.0% RH. If it does not, then Input 2 of the F4 Controller requires calibration.
8. Set the precision source to 20.0 mA.
9. Observe that the Input 2 prompt in the lower display indicates between 99.0% and 101.0% RH. If it does not, then Input 2 of the F4 Controller requires calibration.
10. If calibration of the F4 Controller is necessary, refer to page 9.3 of the "Series F4 User's Manual" and follow the instructions for "Current Process Procedure" for Input 2.
11. When completed, put the sensor wires back on F4 Controller terminals 54 and 58.
12. Note that these steps are not calibrating the humidity sensor, only Input 2 of the F4 Controller.

Theory of Operation

Overview

Refer to the electrical and refrigeration drawings to identify the referenced items described below. The electrical items are referenced with a letter(s) and number. The refrigeration items are referenced with a number only or number followed by a single letter.

Air Heating System

The chamber is heated by an open-element nichrome heater (HT1). The heater is located in the air plenum. The F4 Controller provides a time-proportioned output to a solid state relay (SSR1). This turns the heater on/off as required to maintain the temperature set point. Pilot light PL1 provides an indication on the front panel when the heater is on. Relay CR4, High Heat Interlock, provides staging for the available heat. When the compressors and humidity system is off, full heat of 1,000 Watts is available. Then the compressors or humidity system is on, half heat of 500 Watts is available. A fusible heat limiter (HL) provides failsafe protection against a catastrophic failure by opening the heater circuit at +240°C.

Humidity System

Water is heated by an immersion-type heater (HT2) to generate vapor. The heater is located in the humidifier tank. The F4 Controller provides a time-proportioned output to a solid state relay (SSR2). This turns the humidifier heater on/off as required to maintain the humidity set point. Pilot light PL4 provides an indication on the front panel when the humidifier heater is on.

Water level in the humidifier is maintained by float switch LS1 which is located in the humidifier. LS1 applies power to SSR8 which opens solenoid valve SV6 and energizes the recirculation pump (for the optional recirculation system) to maintain the correct water level in the humidifier.

An additional float switch LS2 disables the immersion heater until a certain minimum water level is reached. The immersion heater has an imbedded thermocouple which is connected to Input 3 of the F4 Controller to control its Alarm 1 output. This provides failsafe protection against a heater failure in the event of a low water condition by opening the humidifier heater contactor C4 if the heater reaches +125°C.

Refrigeration System (non-humidity mode)

In non-humidity mode, cooling is accomplished by a cascade refrigeration system. A cascade refrigeration system consists of two interdependent refrigeration systems. The low-stage provides cooling to the chamber interior through a finned evaporator coil (26), which is located in the air plenum. The high-stage provides cooling to the cascade condenser (21). The cascade condenser is a heat exchanger that has one circuit which is the evaporator of the high-stage, and another circuit which is the condenser of the low-stage.

The high-stage uses refrigerant R-404A. High pressure liquid refrigerant is fed from the condenser (part of 5) through the filter-drier (6), sight glass (7), solenoid valve (18/19B) to the thermostatic expansion valve (20). The thermostatic expansion valve controls the feed of liquid refrigerant to the evaporator circuit of the cascade condenser and, by means of an orifice, reduces the pressure of the refrigerant to the evaporating or low side pressure. The reduction of pressure on the liquid refrigerant causes it to boil or vaporize, absorbing heat which provides a cooling effect. The refrigerant vapor travels through the suction line to the suction accumulator (27) to the compressor (part of 5) suction inlet. The compressor takes the low pressure vapor and compresses it, increasing both the pressure and the temperature. The hot, high pressure vapor is forced out of the compressor discharge valve and into the condenser. As the high pressure vapor passes through the condenser, it is cooled by a fan, which blows ambient air across the finned condenser surface. The vapor condenses into a liquid and the cycle is repeated. The hot gas regulator (9B) is adjusted to keep the suction pressure at 10 PSIG during light loading conditions. A suction line cooling thermostatic expansion valve (11) senses the suction line temperature and injects liquid refrigerant to cool the suction return gas within safe limits.

The Low-Stage uses refrigerant R-508B. High pressure liquid refrigerant is fed from the condenser circuit of the cascade condenser (21), through the filter-drier (34), liquid-line solenoid valve (18/19A), to the capillary tube/strainer assembly (24 and 25). The capillary tube feeds the finned evaporator coil (26), which is located in the air plenum where heat is absorbed to provide a cooling effect within the chamber. The refrigerant vapor travels through the suction line to the compressor (1) suction inlet. The compressor takes the low pressure vapor and compresses it, increasing both the pressure and the temperature. The hot, high pressure vapor is forced out the compressor discharge valve and into the desuperheater (2). As the high pressure vapor passes through the desuperheater, it is air-cooled to remove some sensible heat. Next, the vapor goes through the oil separator (3), which returns any entrained oil back to the compressor's crankcase. The vapor flows through the condenser circuit of the cascade condenser, where it is condensed back into a liquid.

During a high temperature pull down or a continuous bypass condition, it is possible for excessive hot gas to return to the compressor. The suction line cooling thermostatic expansion valve (10) senses the suction line temperature and injects liquid refrigerant to cool the hot gas within safe limits.

The low-stage discharge pressure is kept within safe limits with a bypass pressure switch (14). If the discharge pressure exceeds 280 PSIG, the bypass pressure switch will energize the bypass solenoid valve (18/19C). This will “dump” refrigerant vapor into the expansion tanks (5). This refrigerant is slowly returned from the expansion tanks to the suction line through a strainer / capillary tube (22/23). The expansion tank also provides sufficient volume in the system to keep the “standby pressure” (also known as static or balance pressure), when the system is off, within safe limits.

Both the low- and high-stages each have a high pressure switch (8A, 8B respectively) which turns off the entire refrigeration system in the event of an out of limit condition.

The F4 Controller cycles the low-stage liquid-line solenoid valve (SV1 or 18/19A) on/off through cool control relay CR2 to control the chamber temperature. When SV1 is on, liquid refrigerant flows through the capillary tube and evaporator to cool the chamber. When SV1 is off, the flow stops. The hot gas regulator (9A) is adjusted to keep the suction pressure at 5 PSIG when SV1 is off. This is also called “bypass mode”. Pilot Light PL2 provides an indication on the front panel when the F4 Controller is turning SV1 is on.

The F4 Controller has internal logic to turn the compressors on if cooling is required to maintain the temperature set point. The low-stage compressor turns on 30 seconds after the high-stage turns on through Timing Module TM1. This reduces the system’s starting current, while allowing the cascade condenser to get cool before the low-stage turns on.

Refrigeration System (controlled-humidity mode)

In controlled-humidity mode, cooling and dehumidification is accomplished by a single-stage refrigeration system. Only the R-404A refrigeration system is used, and the R-508B system is disabled. The Humidity mode is enabled through Event 2 (Digital Output 2) in the F4 Controller. Also, the chamber workspace must be between +7°C and +90°C. If the chamber is outside this temperature range, the F4 Controller’s Alarm2 light will turn ON and the chamber will operate as though the Humidity mode was OFF (non-humidity mode).

Dry-bulb cooling is accomplished through the ambient cool capillary tube (30) and the finned ambient coil (15) inside the chamber. The F4 Controller cycles the ambient cool liquid-line solenoid valve (SV3 or 18/19E) on/off through cool relay CR1 to control the chamber temperature. Pilot Light PL2 provides an indication on the front panel when the F4 Controller is turning SV3 is on. A suction limit pressure switch (PS4 or 35) also cycles SV3 to limit peak cooling demands to acceptable limits.

Dehumidification is accomplished through the finned dehumidify coil (17) inside the chamber, which uses a capillary tube (17) as its metering device. The F4 Controller cycles the dehumidify coil liquid-line solenoid valve (SV4, 18/19D) on/off through SSR3 to control the amount of dehumidification. If the compressor is off because no dry-bulb cooling was required, then CR7 and TM2 enable the refrigeration system upon demand for dehumidification.

An evaporator pressure regulator (12) valve keeps the ambient coil and dehumidify coil at 68 psig, thus preventing freezing temperatures. The hot gas regulator (9B) is adjusted to keep the suction pressure at 10 PSIG when both S3 and SV4 are off. A suction line cooling thermostatic expansion valve (11) senses the suction line temperature and injects liquid refrigerant to cool the suction return gas within safe limits.

Troubleshooting

SYMPTOM	CONDITION	CAUSES
Does not heat up at all.	<ol style="list-style-type: none"> 1. If F4 Controller light 1A is ON, circulator fan is ON, the Heat light is OFF. 2. If F4 Controller light 1A is ON, circulator fan is ON, the Heat light is ON. 	<ol style="list-style-type: none"> 1. Solid State Relay SSR1 is defective (open). 2. Heat Limiter HL is open. Heater HT1 is open.
Heats up too slow.	<ol style="list-style-type: none"> 1. Does not meet published specifications. 	<ol style="list-style-type: none"> 1. Chamber is in Humidity Mode. Full heat is only available when Humidity Mode (Event 2) is OFF. 2. Chamber interior is overloaded. Circulator motor is not turning. Port plug is not in port. Verify that input voltage is within tolerance.
Heat is on all the time.	<ol style="list-style-type: none"> 1. If F4 Controller light 1A is OFF, the Heat light is ON. 	<ol style="list-style-type: none"> 1. Solid State Relay SSR1 is defective (shorted). Defective output 1A on F4 Controller.
Does not cool at all.	<ol style="list-style-type: none"> 1. If F4 Controller light 1B is ON, the DigitalOut prompt shows an “8”, both compressors are OFF. 2. If F4 Controller light 1B is ON, the Cool light is ON. Compressors are ON. 	<ol style="list-style-type: none"> 1. Pressure switch PS1 or PS2 is tripped. 2. Solenoid valve SV1 (or SV3 if in Humidity mode) may be defective in closed position. Refrigeration leak, plugged capillary tubes.
R-404A pressure switch DPS1 trips. (on rear right side)	<ol style="list-style-type: none"> 1. Trips after operating for a while. 2. Trips immediately after turn on. 	<ol style="list-style-type: none"> 1. Ambient temperature may be too high, over 90°F. Dirty condenser, inadequate clearance from back of chamber to wall. 2. Low charge (leak).
R-404A sightglass has bubbles or does not look full.	<ol style="list-style-type: none"> 1. During all running conditions. 2. Only when cool light is cycling. 	<ol style="list-style-type: none"> 1. Low charge (leak). 2. No problem. This is normal.
Cools too slowly or does not reach -73°C.	<ol style="list-style-type: none"> 1. R-508B standby is ok, no bubbles in R-404A sightglass. 	<ol style="list-style-type: none"> 1. Chamber interior is overloaded. Test sample is energized, giving off heat. Circulator motor is not turning. Port plug is not in port. Door is not sealing completely. Ice on evaporator.

Chapter 8 – Maintenance

SYMPTOM	CONDITION	CAUSES
<p>Temperature readout on F4 Controller varies more than $\pm 0.5^{\circ}\text{C}$ or 1°C total.</p>	<ol style="list-style-type: none"> 1. If tuning PID control parameters in F4 Controller were changed. 2. If tuning PID control parameters in F4 Controller are as shipped from TestEquity. 3. If tuning PID control parameters in F4 Controller are as shipped from TestEquity and only occurs in cool mode. 	<ol style="list-style-type: none"> 1. Re-enter values as shipped from TestEquity. 2. Control parameters may need to be changed for your unique test conditions. 3. Solenoid valve SV1 (or SV3 if in Humidity mode) may be defective.
<p>Compressors turn on and off too frequently.</p>	<ol style="list-style-type: none"> 1. If compressor control parameters in F4 Controller were changed. 2. If compressor control parameters in F4 Controller are as shipped from TestEquity. 	<ol style="list-style-type: none"> 1. Re-enter values as shipped from TestEquity. 2. Solenoid valve SV1 (or SV3 if in Humidity mode) may be defective in the open position.

Refrigeration System Charging Instructions

⚠ WARNING: Repair of the refrigeration system must be performed only by a properly trained mechanic who is experienced in repairing cascade refrigeration systems. Do NOT substitute any component. Do NOT substitute refrigerants. Improper repairs will void the warranty.

These instructions are intended as guidelines for repairing TestEquity chambers. Details such as how to attach a gauge manifold are not covered. These are NOT do-it-yourself instructions!

R-404A High-Stage Charge

TestEquity does NOT recommend charging the system by relying on a clear sight glass only. Although a clear sight glass generally means the system is fully charged, it can be misleading. For example, if the system is charged on a cool day or with an empty chamber, it could be undercharged for hot days or with a heavy load. The proper charging procedure is as follows:

1. Repair any leaks before recharging.
2. Attach a vacuum pump and manifold gauge to the suction and discharge ports.
3. Evacuate the system to at least 100 microns. DO NOT GUESS! You must use a micron gauge.
4. Use a charging scale to weigh in 3 pounds of R-404A.
5. Verify the cooling performance as outlined in “How to verify the chamber performance”.

NOTE: If the F4 Controller is cycling (Cool Light cycles on/off), the sightglass may appear 1/2 to 2/3 full. This is normal.

R-508B Low-Stage Charge

1. Repair any leaks before recharging.
2. Attach a vacuum pump and manifold gauge to the suction, discharge, and expansion tank ports. Attaching to the expansion tank is very important because it is otherwise very difficult to evacuate the tank through the pressure regulator or capillary tube that connects it to the system.
3. Evacuate the system to at least 100 microns. Do NOT guess! You must use a micron gauge.
4. Do NOT put any additives in the system. Pentane is NOT necessary or desirable.
5. Charge the system until the standby pressure is 125 PSIG. Allow time for the charge to equalize as read on the suction and discharge gauges. This is 5 PSIG higher than the target amount of 120 PSIG. See NOTE below.
6. Verify the cooling performance as outlined in “How to verify the chamber performance”.

NOTE: If the low-stage has been evacuated and recharged, the standby pressure should be rechecked after 24 hours to make sure it is 120 PSIG. This is because the refrigerant mixes with the POE oil in the compressor, causing a lower standby pressure than was initially observed. Do not mistake this initial loss of pressure with a leak. After verifying that there is no leak, you may need to top-off the charge if the pressure is too low.

Recommended Spare Parts

Replacement parts are available from TestEquity. Parts are generally in-stock and ready for immediate shipment. Next-day delivery is always available. If you cannot risk being out of service for even one day, then you should purchase critical spare parts in advance. Although most parts are standard and available from a variety of local distributors, some parts are either harder to find or custom.

The following is a list of the kinds of parts that you may want to purchase in advance.

Electrical Parts

- Contactors
- Relays
- Fuses
- Heat Limiter
- Circulator Motor and Fan
- Switches

Refrigeration Parts

- Solenoid Valves
- Expansion Valves
- Regulator Valves

Chapter 8 – Maintenance

Major Electrical Parts

Description	Mfr	Mfr Part No.	Ref #	Part #	Qty	UOM
Air Heater	CUSTOM	200272	HT1	200272	1	ea
Arc Suppressor	ITW Paktron	104MACQRL150	AS1-9	200296	9	ea
Audible alarm	Floyd Bell	MC-09-201-Q	AL1	200005	1	ea
Circulator Motor Kit	CUSTOM	CUSTOM	FM2	100585	1	ea
Contact, 1 Pole, 30A, 120V Coil	Hartland Controls	HCC-1XT02AA	C1-4	200237	4	ea
Heat Limiter	Thermodisc	G5A01240C	HL	200070	1	ea
Humidifier Heater	CUSTOM	200270	HT2	200270	1	ea
Humidity Sensor	Vaisala	HMM100	RHS	200320	1	ea
Level Switch	Gems	LS-7 PP	LS1, 2	300780	2	ea
Limit Controller	Watlow	PM6L1AJ-AAAABAB	TCR2	200301	1	ea
Line Cord	Intl. Config.	80560		200205	1	ea
Pilot Light	Chicago Miniature	6063-001-534R	PL1-4	222280	4	ea
Relay, Octal DPDT 10A 120VAC	Idec	RR2P-UCAC120	CR1-6	200292	6	ea
Relay, Solid State 5A	Omron	G3NA-205B-DC5-24	SSR9-12	200032	4	ea
Relay, Solid State 5A, AC input	Carlo Gavazzi	RM1A23A25	SSR8	200268	1	ea
Relay, Solid State, 10A, 24VDC In	Omron	G3NE-210T-US DC24	SSR1-3	200177	3	ea
Relay, Solid State, 10A, 5VDC in	Omron	G3NE-210T-US DC5	SSR4-7	200129	4	ea
Relay, SPDT	Omron	G2R-1-T-AC120	CR7	200160	1	ea
Lamp	Philips	T22, 125-130V, 15W, E14	LT1	200203	1	ea
Solenoid Valve, Humidifier Fill	Asco	8262G20	SV6	200183	1	ea
Switch	Carlingswitch	LRA211-RA-B/125N	SW1, 3	200023	2	ea
Switch, ON-OFF-ON	Carlingswitch	RC911-RA-B-0-N-XLR1	SW2	200275	1	ea
Temperature/Humidity Controller	Watlow	F4DH-CKCC-01AC	TCR1	200084	1	ea
Timing Module, Off Delay, 60 Sec	Airotronics	TH3ML1060SC	TM2	200244	1	ea
Timing Module, On Delay, 30 Sec	Airotronics	THC1030SC	TM1	200243	1	ea
Transformer, 20VAC	Hammond	166D20	TR1	200087	1	ea
Chart Recorder Option						
Recorder, 2 Pen, 10"	Honeywell	DR4302-0000-G0100	RCD1	200098	1	ea
Paper, -90 to 210 C, 0 to 100	Graphic Controls	32002974 (Custom)		200155	1	ea
Pen, Purple, Six Pack	Honeywell	30735489-007		200097	1	ea
Pen, Red, Six Pack	Honeywell	30735489-002		200099	1	ea

Chapter 8 – Maintenance

Major Refrigeration Parts

Description	Mfr	Mfr Part No.	Ref #	Part #	Qty	UOM
Accumulator	CUSTOM	100345	27	100345	1	ea
Ambient Coil	CUSTOM	100505	15	100505	1	ea
Capillary Tube, Amb Cool, 0.050	J/B Industries	TC50	30	100019	60	in
Capillary Tube, Bleed, 0.050	J/B Industries	TC50	23	100019	36	in
Capillary Tube, DH, 0.042	J/B Industries	TC42	16	100340	96	in
Capillary Tube, Equalizer, 0.031	J/B Industries	TC31	28	100320	120	in
Capillary Tube, Main Cool, 0.050	J/B Industries	TC50	25	100019	60	in
Cascade Condenser	Flatplate	CUSTOM	21	100601	1	ea
Check Valve	Henry	116004	13A, 13B	100329	2	ea
Compressor, 1/2 HP	Copeland	AFE13C3E-IAA-201	1	100347	1	ea
Condensing Unit, 1/2 HP	Copeland	M4FL-H051-IAA-212	5	100602	1	ea
Dehumidification Coil	CUSTOM	100506	17	100506	1	ea
Desuperheater	CUSTOM	100508	2	100508	1	ea
Discharge Pressure Limit	Johnson Controls	P20EA-1D	14	100342	1	ea
EPR Valve	Sporlan	ORIT-6-30/100	12	100332	1	ea
Expansion Tank	CUSTOM	100346	36	100346	2	ea
Expansion Valve, R404A Main	Danfoss	068U2317	20	100471	1	ea
Expansion Valve, Suction Cooling	Danfoss	068U202700	10, 11	100314	2	ea
Filter Drier	Danfoss	023Z5048	6, 34	100524	2	ea
High Pressure Cutout	Johnson Controls	P20DB-1D	8A, 8B	100341	2	ea
Hot Gas Bypass Regulator	Sporlan	ADRI-1/4-0/55	9A, 9B	100497	3	ea
Low Stage Evaporator	CUSTOM	100504	26	100504	1	ea
Oil Separator	Temprite	900	3	100536	1	ea
Orifice	Danfoss	068U1033	p/o 20	100607	1	ea
Pressure Control, Suction Limiter	Johnson Controls	P70EA-10C	35	100326	1	ea
Purge Solenoid Valve	Asco	8262G22	SV7	100305	1	ea
Sight Glass	Henry	MI-30-1/4S	7	100608	1	ea
Solenoid Coil	Sporlan	OMKC-1-120/50-60	SV1-5	100344	5	ea
Solenoid Valve, Rapid Cycle	Sporlan	XWG	19A-E	100343	5	ea
Strainer	Supco	S211	29	100606	3	ea

General Parts

Description	Mfr	Mfr Part No.	Ref #	Part #	Qty	UOM
Door Gasket, Inner	CUSTOM	CUSTOM		382236	1	ea
Door Gasket, Outer	CUSTOM	CUSTOM		382235	1	ea
Door Latch, Chamber Workspace	Southco	A7-10-301-20		300216	1	ea
Port Plug, Foam, 4"	CUSTOM	CUSTOM		300534	2	ea
Shelf with 4 Clips	CUSTOM	CUSTOM		TE-0231	1	ea
Shelf Retainer Clip	Kason	Style 66, #0066000008		300015	4	ea
Window, Heated	CUSTOM	CUSTOM		300709	1	ea

Series F4 Controller Setup Parameters

- △ **CAUTION:** The Series F4 Controller has been properly configured by TestEquity to match the chamber’s system requirements and to perform optimally over a wide range of operating conditions. Improper modifications to these setup values can result in erratic performance and unreliable operation. Setup examples in the “Series F4 User’s Manual” are NOT applicable to this chamber. Do not attempt to modify the setup values, unless you thoroughly understand what you are doing. If there is any doubt, please call TestEquity before proceeding.
- △ **CAUTION:** The “Series F4 User’s Manual” is a general manual and is written by the manufacturer, Watlow, for a wide variety of applications and configurations. Not all features or functions are applicable. Only the capabilities of a model F4DH-CKCC-01, as described on page A.7 of the “Series F4 User’s Manual” are applicable. “Cascade Control” as described on page 3.6 of the “Series F4 User’s Manual” is not applicable in this configuration. The “Retransmit” function is available as an option.
- △ **CAUTION:** The Series F4 alarms are configured for internal protection of the humidity system. Do NOT change this configuration under any circumstances. The independent EZ-Zone Limit Controller functions as the main system and product protection device.
- △ **CAUTION:** NEVER select “Full Defaults” in the Factory/Test Menu. “Full Defaults” are NOT the TestEquity configuration parameters for this chamber. If you select “Full Defaults”, you must reconfigure all System and Operation Parameters as documented in the TestEquity manual, NOT the “Series F4 User’s Manual”.

TestEquity has configured the F4 Controller with the parameters as documented on the following pages.

Series F4 Setup Parameters

<p>System Main Page\Go to Setup\System GSB 1 Source Input 1 Guar. Soak Band 1 3.0 °C (5.4 if °F) GSB 2 Source Input 2 Guar. Soak Band 2 5.0 % Current Time (local time) Current Date (local date) PID Units US °F or °C °C Show °F or °C Yes, Upper Display Ch1 Autotune SP 90 % Ch2 Autotune SP 90 % Input 1 Fail 0 % Input 2 Fail 0 % Open Loop Ch1 Off Open Loop Ch2 Off Power Out Time 10 sec Power-Out Action Continue</p> <p>Analog Input Main Page\Go to Setup\Analog Input 1 Sensor Thermocouple Type T Choose Decimal 0.0 SP Low Limit -75.0 °C (-103.0 if °F) SP High Limit 175.0 °C (347.0 if °F) Calibration Offset 0.0 °C Filter Time 1.0 sec Error Latch Self-Clear</p> <p>Main Page\Go to Setup\Analog Input 2 Sensor Process Type 0 to 20mA Units % rh Decimal 0.0 Scale Low 0.0 % Scale High 100.0 % Scaling Normal Scaling SP Low Limit 0.0 % SP High Limit 98.0 % Calibration Offset 0.0 Filter Time 1.0 sec Error Latch Self-Clear</p> <p>Main Page\Go to Setup\Analog Input 3 Sensor Thermocouple Type J Decimal 0 SP Low Limit 0 °C (32 if °F) SP High Limit 815 °C (1500 if °F) Calibration Offset 0 °C Filter Time 1.0 sec Error Latch Latch Cascade No Cascade</p> <p>Digital Input Menu Main Page\Go to Setup\Digital Input (1-4) Name No Function Off</p>	<p>Control Output Main Page\Go to Setup\Control Output 1A Function Heat Choose Cycle Time Fixed Time Enter Cycle Time 3.0 sec Hi Power Limit 100 % Low Power Limit 0 %</p> <p>Main Page\Go to Setup\Control Output 1B Function Cool Choose Cycle Time Fixed Time Cycle Time 6.0 sec Hi Power Limit 100 % Low Power Limit 0 %</p> <p>Main Page\Go to Setup\Control Output 2A Function Heat Choose Cycle Time Fixed Time Cycle Time 2.0 sec Hi Power Limit 100 % Low Power Limit 0 %</p> <p>Main Page\Go to Setup\Control Output 2B Function Cool Choose Cycle Time Fixed Time Cycle Time 10.0 sec Hi Power Limit 100 % Low Power Limit 0 %</p> <p>Alarm Output Main Page\Go to Setup\Alarm Output 1 Name HUM OVRTMP Alarm Type Process Alarm Source Input 3 Latches Latches Silencing No Alarm Hysteresis 75.0 °C (167.0 if °F) Alarm Sides High Alarm Logic Open on Alarm Show Message Yes on Main Page</p> <p>Main Page\Go to Setup\Alarm Output 2 Name HUM RANGE Alarm Type Process Alarm Source Input 1 Latches Self-Clears Silencing No Alarm Hysteresis 2.0 °C (3.6 if °F) Alarm Sides Both Alarm Logic Open on Alarm Show Message No</p> <p>Retransmit Output (if retransmit option is ordered) Main Page\Go to Setup\Retransmit Output 1 Retransmit Source Input 1 Analog Range 0-5V Low Scale -75.0°C (-103.0 if °F) High Scale 175.0°C (347.0 if °F) Scale Offset 0.0</p> <p>Main Page\Go to Setup\Retransmit Output 2 Retransmit Source Input 2 Analog Range 0-5V Low Scale 0.0 High Scale 100.0 Scale Offset 0</p>	<p>Digital Output Main Page\Go to Setup\Digital Output 1 Name Yes Name Digital Out. CONDITION Function Event Output</p> <p>Main Page\Go to Setup\Digital Output 2 Name Yes Name Digital Out. HUMIDITY Function Event Output</p> <p>Main Page\Go to Setup\Digital Output 3 Name Yes Name Digital Out. PURGE Function Event Output</p> <p>Main Page\Go to Setup\Digital Output (4-7) Name No Function Event Output</p> <p>Main Page\Go to Setup\Digital Output 8 Name No Function Compressor Comp. On % Pwr. -2% Comp. Off % Pwr. 2% Comp. Off Delay 60 sec Comp. On Delay 10 sec</p> <p>Communications Menu Main Page\Go to Setup\Communications Baud Rate 9600 Address 1</p> <p>Custom Main Page Main Page\Go to Setup\Custom Main Page P1 Input 2 P2 Current File P3 Current Step P4 Set Point 1 P5 Set Point 2 P6 Step Type P7 Target SP1 P8 Target SP2 P9 Wait For Status P10 Jump Count P11 Time Remaining P12 Digital Outs P13 % Power 1 P14 % Power 2 P15 Time P16 Date</p> <p>Process Display Menu Main Page\Go to Setup\Process Display Choose Input 1 only</p> <p>Static Message Menu Main Page\Go to Setup\Static Message Message 1 TESTEQUITY 123H</p>
---	--	---

Series F4 Operations Parameters

<p>PID Set Channel 1 Main Page\Go to Operations>Edit PID\PID Set Channel 1 PID Set (1-5)</p> <p>Proportional Band A 5.0 °C (9.0 if °F) Reset A 0.10 /min Rate A 0.00 min Dead Band A 0.0 °C Hysteresis 0.0 Proportional Band B 5.0 °C (9.0 if °F) Reset B 0.10 min Rate B 0.00 min Dead Band B 0.0 Hysteresis 0.0</p> <p>PID Set Channel 2 Main Page\Go to Operations>Edit PID\PID Set Channel 2 PID Set (6-10)</p> <p>Proportional Band A 10.0 % Reset A 0.01 min Rate A 0.00 min Dead Band A 0.0 % Hysteresis 0.0 Proportional Band B 10.0 % Reset B 0.20 min Rate B 0.00 min Dead Band B 0.0 % Hysteresis 0.0</p>	<p>Alarm Setpoints Menu Main Page\Go to Operations\Alarm Setpoints</p> <p>HUM OVRTMP (Alarm1) Alarm1 Low SP 0 °C (32 if °F) Alarm1 High SP 125 °C (257 if °F)</p> <p>HUM RANGE (Alarm2) Alarm2 Low SP 7.0 °C (44.6° if °F) Alarm2 High SP 90.0 °C (194.0 if °F)</p> <p>NOTE: The Series F4 alarms are configured for internal protection of the humidity system. Do NOT change this configuration under any circumstances. The independent EZ-Zone Limit Controller functions as the main system and product protection device.</p>
--	---

Series F4 Set Lockout Parameters

The Series F4 Controller has several levels of security to prevent unauthorized users from changing critical configuration parameters. Only the Set Point and Profile menus have “Full Access”. The “Autotune PID” menu is hidden because this function should never be used, as it will result in erratic performance. The “Alarm SP” is also hidden because the F4 alarms are configured for internal protection of the humidity system and must never be changed. TestEquity has configured all other menus to “Password”, and have protected them with a password.

TestEquity does not recommend that these security levels be changed. You may need to gain access to Setup Page in order to change from °C to °F display, or to change the time or date; or access to the Factory page to perform a calibration. You must call TestEquity at 877-512-3457 or 805-480-0638 to obtain the password.

Set Lockout Menu

Main Page\Go to Factory\Set Lockout

Menu	Lock
Set Point	Full Access
Oper. Autotune PID	Hidden
Oper. Edit PID	Password
Oper. Alarm SP	Hidden
Profile	Full Access
Setup	Password
Factory	Password

EZ-Zone Limit Controller Setup Parameters

△ CAUTION: The EZ-Zone Limit Controller has been properly configured by TestEquity to match the chamber’s system requirements. Improper modifications to these setup values can result in erratic performance and unreliable operation. Do not attempt to modify the setup values, unless you thoroughly understand what you are doing. If there is any doubt, please call TestEquity before proceeding.

Setup Menu

Prompt	Function	Setting	Alternate Setting
LoC	Lockout Menu	2	See NOTE 1 below
SEn	Sensor Type	tC	Do Not Change
L_{in}	Linearization	t	Do Not Change
dEC	Decimal	0	Alt. “0.0”
C_F	°C or °F	C	Alt. “F”
rLo	Range Low	-75	Do not make any lower
rHi	Range High	180	Do not make any higher
Fn2	Output 2 Function	L₁₇₇	Do Not Change
L_{Sd}	Limit Sides	both	Alt. “high” (High only) or “LoW” (Low only)
L_{hY}	Limit Hysteresis	2	Change not recommended
ALY	Alarm Type	oFF	Do Not Change
PAR₁	Upper Display	ACP_u	Alt. “none”
PAR₂	Lower Display	L_{SE}	Alt. “Lh.s” (High Set Point) or “LL.S” (Low Set Point)
AdS	Zone Address	1	Not functional for this application

NOTE 1: The Lockout Menu **LoC** sets the security clearance level as follows:

- 1** Operations Menu, read only
- 2** Operations Menu, set point read/write
- 3** Operations Menu, set point read or write (same as level 2)
- 4** Operations Menu, full access read/write (required to access Calibration Offset below)
- 5** Operations Menu and Setup Menu full access (required to access Setup Menu and Calibration Offset below)

Operations Menu

Prompt	Function	Setting	Alternate Setting
LLS	Low Set Point	-75	Appropriate Low Limit Set Point
LhS	High Set Point	180	Appropriate High Limit Set Point
.CR	Calibration Offset	0	Calibration Offset as required (see NOTE 2 below)

NOTE 2: LoC parameter in Setup Menu must be set for 4 or 5 to access the Calibration Offset parameter.

Chapter 9 - Warranty

TestEquity LLC Limited Warranty

TestEquity LLC (TestEquity) warrants Environmental Chambers (Equipment) manufactured by TestEquity and supplied under this contract to be free from defects in materials and workmanship under normal use and proper maintenance.

TestEquity will repair or replace any defective part for a period of THREE YEARS from the date of invoice. TestEquity reserves the right to require any defective part be returned, freight prepaid, to TestEquity's factory or to inspect any defective part at the Purchaser's site. TestEquity shall have sole discretion to determine whether any part is defective and whether any defective part will be repaired or replaced. This limited warranty shall extend to any standard chamber accessory and component part which is normally sold by TestEquity. Non-standard accessories and component parts specified by the Purchaser shall be warranted only to the extent of the original manufacturer's warranty, if any exists.

If the repair or replacement is performed in the FIRST YEAR from the date of invoice, TestEquity will also pay for the labor associated with the repair at the Purchaser's site, subject to TestEquity's prior approval. During the SECOND and THIRD YEAR of the warranty period, Purchaser will be responsible for the installation and cost of installation of replacement or repaired parts, and the cost of refrigerant. Purchaser shall notify TestEquity in writing of any alleged defect within 10 days after its discovery within the warranty period. TestEquity reserves the right to satisfy the labor portion of this limited warranty either through its own service personnel or an authorized agent. In order to provide expeditious service, TestEquity reserves the right to satisfy its limited warranty obligation by sending replacement parts to be installed by the Purchaser if they can be installed easily without special tools or training. TestEquity reserves the right to satisfy this limited warranty by requiring the Purchaser to return the Equipment to TestEquity when such return is feasible.

The following parts are excluded from this limited warranty and are sold as-is or are considered expendable: interior light bulb, viewing window, paint and cosmetic surface finishes and treatments, port plugs, refrigerant.

This limited warranty shall extend in full to Equipment installed within continental United States and Canada. For all other locations, Purchaser is responsible for all labor costs for repairs or parts installation, and for all shipping costs associated with providing replacement parts.

This limited warranty does not cover: (1) Defects or damages arising as the result of shipment by common carriers or private transportation, unless TestEquity undertakes shipment and transportation of the Equipment to Purchaser's site or contractually assumes the risk of damage to the Equipment in shipment; (2) Defects or damages arising out of, or as the result, of mishandling, modification, or improper start up, installation or maintenance of the Equipment (including start up, installation or maintenance not in accordance with TestEquity's written procedures); (3) Defects or damages resulting from, or arising out of, abuse, misuse, neglect, intentional damage, accident, fire, flood, earthquake, or any other act of God.

This warranty as to Equipment is LIMITED to repair or replacement of parts or Equipment in the determination of TestEquity LLC THE FORGOING LIMITED WARRANTY IS IN LIEU OF ALL OTHER WARRANTIES INCLUDING THE IMPLIED WARRANTIES OF FITNESS FOR A PARTICULAR PURPOSE AND MERCHANTABILITY. TestEquity LLC DISCLAIMS ANY LIABILITY FOR ANY DAMAGES RESULTING FROM DELAY OR LOSS OF USE IN SERVICE OR REPAIR, OR FOR INCIDENTAL OR CONSEQUENTIAL DAMAGES ARISING OUT OF OR IN CONNECTION WITH THE USE OR PERFORMANCE OF THE EQUIPMENT, EXCEPT AS STATED IN THIS PARAGRAPH.

This limited warranty cannot be modified in any way except in writing by both TestEquity and Purchaser. Invalidation of any one or more of the provisions of this limited warranty shall in no way affect any of the other provisions hereof, which remain in full force and effect.

This limited warranty shall be extended only to the first Purchaser of this Equipment and is not transferable.

Chapter 10 – Drawings

Electrical Subpanel Component Location

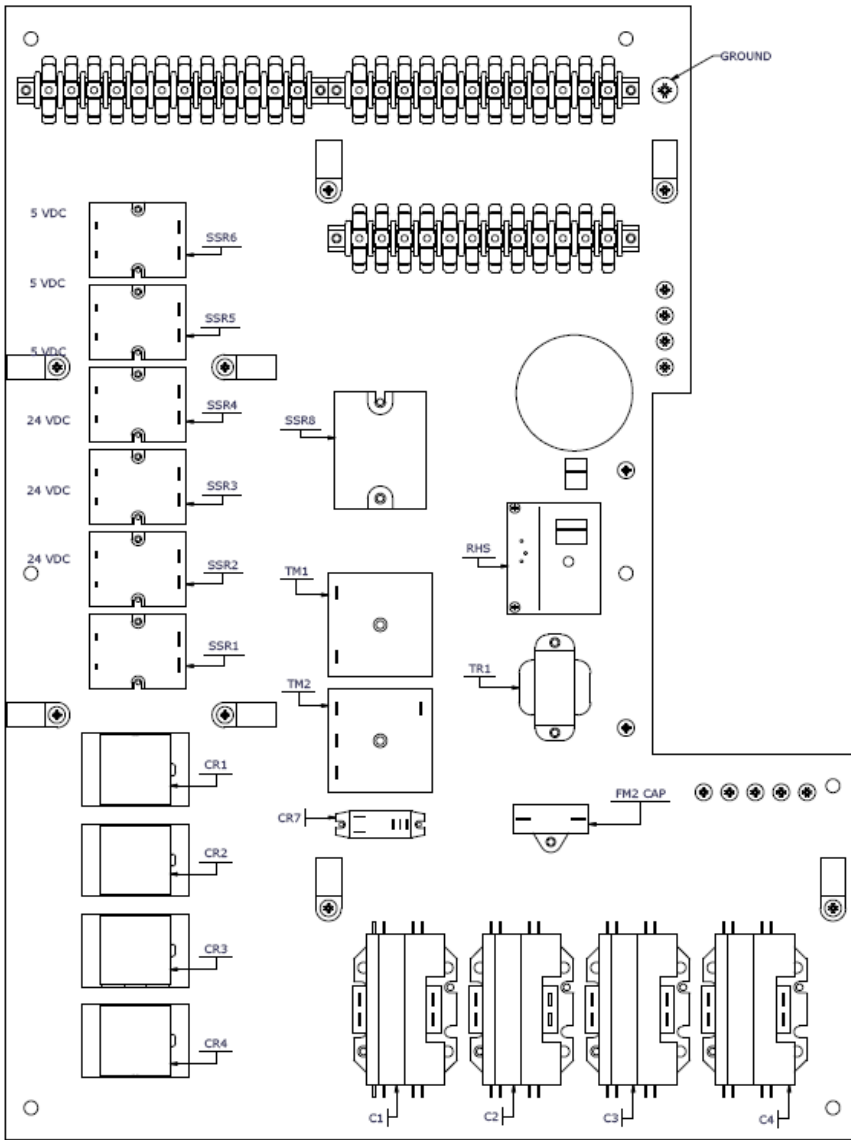

Main Subpanel

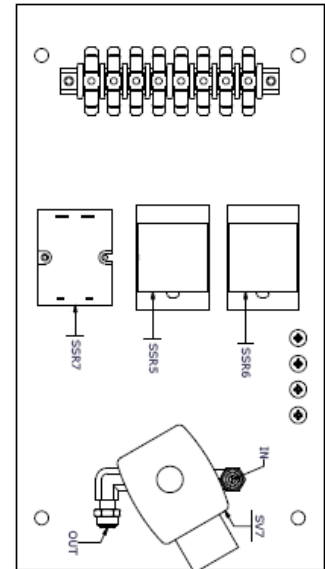

Purge Subpanel