

# Agilent Overvoltage Protection in Power Supplies

## Application Note



## Introduction

Overvoltage (OVP) is an important security feature in power supplies. By using this feature, we can protect the device under test (DUT) from a higher voltage than the DUT was designed to handle. OVP is useful in a variety of applications in electronics manufacturing and the educational market.

Overvoltage protection is also available if required during constant current operation. The constant voltage/constant current (CV/CC) and constant voltage/current limit (CV/CL) automatic crossover circuitry is ideal for these purposes because it allows you to select the maximum safe current or voltage for your particular load device.

The new Agilent U8000 Series power supply is short-circuit proof and can operate under any current overload condition indefinitely, without the risk of internal damage. It uses an overvoltage crowbar in which the crowbar circuit is connected across the output terminals. This provides protection against any output overvoltage condition that might occur because of operator error or failure within the power supply or load.

This application note explains the architecture of OVP and describes its applications. It discusses what you need to pay attention to when you use this feature.

## Overvoltage Crowbar

An operator error or a component failure in the regulating feedback loop can drive a power supply's output voltage to many times its preset value. The function of the crowbar circuit is to protect the load against this possibility. The circuit ensures that the power supply voltage across the load will never exceed a preset limit. This protection is valuable because of the extreme voltage sensitivity of today's semiconductor devices.

The basic elements used in most crowbars are some method of sensing the output voltage, a silicon controlled rectifier (SCR) that will short the output, and a circuit that will reliably trigger the SCR within a time period that is brief enough to avoid damage to the load.

The sensing circuit can be a simple bridge or voltage divider network that compares the output voltage to the internal crowbar reference voltage. The best trigger circuit is the one that turns on the SCR most quickly. The fastest SCR turn-on is accomplished by a fast rise-time pulse circuit such as a blocking oscillator or Schmitt trigger.

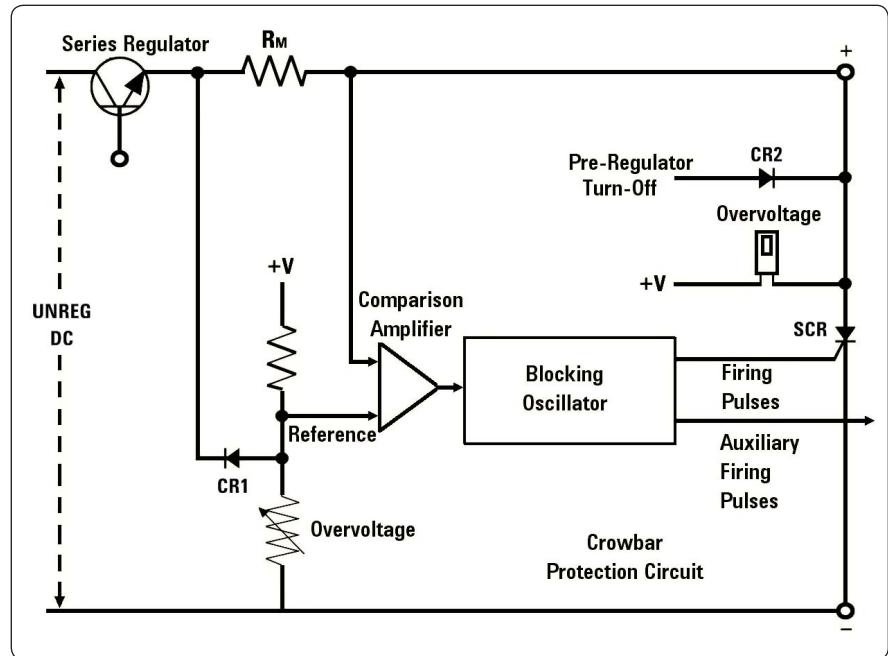

Figure 1. General crowbar overvoltage protection circuit

Figure 1 shows the general crowbar overvoltage protection circuit. The circuit compares the output voltage with a reference voltage +V. The overvoltage potentiometer adjusts the reference voltage on the comparison amplifier and sets the voltage level at which the crowbar will be activated.

Normally, the overvoltage control is located on the front panel and can be adjusted from approximately 20% to 120% of the maximum rated output voltage of the power supply. When the output voltage exceeds the reference, the comparison amplifier triggers the blocking oscillator, which then sends firing pulses to the SCR. When the SCR fires, it places a very low impedance across the output, reducing the voltage to near-zero.

Crowbar circuits have several beneficial features:

- An overvoltage indicator appears when the SCR fires; the indicator conducts a holding current to prevent the SCR from oscillating on and off.
- The crowbar circuit creates an extra current path during normal operation of the supply, thus changing the current that flows through the current monitoring resistor. The diode keeps this extra current at a fixed level where compensation can then be made in the constant-current comparator circuit.
- In pre-regulate supplies, the crowbar turns off the pre-regulator circuit when the SCR fires, reducing the voltage drop across the series regulator and the current flow through the SCR.
- An auxiliary winding is included on the blocking oscillator transformer for connection to an additional crowbar. Tandem crowbar operation is then available for coincident firing of all crowbars in a system.

## OVP application

### Connect power supply in series

One of the OVP application is to connect power supplies in series for higher voltage output. Set the OVP shutdown voltage in each unit so that it shuts down at a voltage higher than its output voltage during auto-tracking operation. When a master unit shuts down, it programs any slave units to zero output. When a slave unit shuts down, it shuts down only itself, and the master continues to supply output voltage.

### Battery charging

Some power supplies contain an overvoltage protection circuit, which will short the power supply's output if an overvoltage condition occurs. The OVP circuit is typically a crowbar SCR that operates independently of the power supply's regulation circuit. When you use a power supply to charge a battery, it is possible to charge the battery to a voltage greater than the OVP limit. Once the OVP limit is exceeded, the SCR will short the output and continuously sink a large current from the source, possibly damaging the power supply. To avoid damaging the power supply, connect a diode in series with the power supply to ensure that current only flows out of the power supply.

### False shutdowns

The voltage at the output terminal can be increased inadvertently in a variety of ways such as from the front panel or by a change in the load. False OVP shutdowns can occur if the OVP shutdown voltage has been set too close to the power supply's operating voltage. You should set the OVP shutdown voltage 4% higher or at least +2.0 V above the desired output voltage to avoid false shutdowns from load-induced transients.

False OVP shutdowns occur commonly when the OVP limit is set too close to the output voltage when using remote sensing. Remote sensing will increase the voltage at the output terminals to compensate for the voltage drop in the wire between the power supply and the DUT. A longer cable can create significant voltage drops due to low resistance. Another possible cause of OVP false shutdowns is strong electrostatic discharge (ESD) applied to the power supply, which can trip the OVP limit and eventually crowbar the output, protecting output loads from the hazardous ESD current.

## Conclusion

Overvoltage protection is an important feature for power supplies. It can protect your DUT from a voltage higher than it was designed to handle.

By knowing the architecture of a power supply's overvoltage crowbar circuit and its applications, you can easily apply and fully utilize this feature for many applications.

## Agilent Email Updates

### [www.agilent.com/find/emailupdates](http://www.agilent.com/find/emailupdates)

Get the latest information on the products and applications you select.



### [www.lxistandard.org](http://www.lxistandard.org)

LXI is the LAN-based successor to GPIB, providing faster, more efficient connectivity. Agilent is a founding member of the LXI consortium.

## Agilent Channel Partners

### [www.agilent.com/find/channelpartners](http://www.agilent.com/find/channelpartners)

Get the best of both worlds: Agilent's measurement expertise and product breadth, combined with channel partner convenience.

## Remove all doubt

Our repair and calibration services will get your equipment back to you, performing like new, when promised. You will get full value out of your Agilent equipment through-out its lifetime. Your equipment will be serviced by Agilent-trained technicians using the latest factory calibration procedures, automated repair diagnostics and genuine parts. You will always have the utmost confidence in your measurements. For information regarding self maintenance of this product, please contact your Agilent office.

Agilent offers a wide range of additional expert test and measurement services for your equipment, including initial start-up assistance, onsite education and training, as well as design, system integration, and project management.

For more information on repair and calibration services, go to:

[www.agilent.com/find/removealldoubt](http://www.agilent.com/find/removealldoubt)

[www.agilent.com](http://www.agilent.com)  
[www.agilent.com/find/basicpower](http://www.agilent.com/find/basicpower)

For more information on Agilent Technologies' products, applications or services, please contact your local Agilent office. The complete list is available at:

[www.agilent.com/find/contactus](http://www.agilent.com/find/contactus)

### Americas

Canada	(877) 894 4414
Latin America	305 269 7500
United States	(800) 829 4444

### Asia Pacific

Australia	1 800 629 485
China	800 810 0189
Hong Kong	800 938 693
India	1 800 112 929
Japan	0120 (421) 345
Korea	080 769 0800
Malaysia	1 800 888 848
Singapore	1 800 375 8100
Taiwan	0800 047 866
Thailand	1 800 226 008

### Europe & Middle East

Austria	43 (0) 1 360 277 1571
Belgium	32 (0) 2 404 93 40
Denmark	45 70 13 15 15
Finland	358 (0) 10 855 2100
France	0825 010 700* *0.125 €/minute
Germany	49 (0) 7031 464 6333
Ireland	1890 924 204
Israel	972-3-9288-504/544
Italy	39 02 92 60 8484
Netherlands	31 (0) 20 547 2111
Spain	34 (91) 631 3300
Sweden	0200-88 22 55
Switzerland	0800 80 53 53
United Kingdom	44 (0) 118 9276201
Other European Countries:	<a href="http://www.agilent.com/find/contactus">www.agilent.com/find/contactus</a>

Revised: October 1, 2009

Product specifications and descriptions in this document subject to change without notice.

© Agilent Technologies, Inc. 2010  
Printed in USA, February 24, 2010  
5989-9395EN



Agilent Technologies