

Scalar Network Analysis with U2000 Series USB Power Sensors

Application Note

Overview

The Agilent U2000 Series USB power sensor is a compact, light weight instrument that performs accurate RF and microwave power measurements. Used with a power splitter, coupler, and signal source, the U2000 provides scalar network analysis (SNA) capability. This SNA capability allows you to perform stimulus-response measurements such as gain, insertion loss, frequency response, and return loss. These measurements are made to characterize the transmission or reflection coefficient of devices such as cables, filters, amplifiers, and complex systems encompassing multiple components, devices, and cables.

Some examples of stimulus-response measurements are:

- 3 dB bandwidth of a bandpass filter
- gain and return loss of an amplifier
- return loss of an antenna
- flatness of a low pass filter
- frequency response of a cable

Stimulus-response measurements require a source to stimulate the device under test (DUT) and a receiver (in this case, a power sensor) to analyze the DUT's frequency response characteristics. While other Agilent power meters and sensors may also be used for operations above 26.5 GHz, for simplicity, this application note only focuses on the use of USB sensors.

This application note shows how to make accurate stimulus-response measurements using:

- U2000 Series USB power sensors
- ESG/MXG/PSG signal generators
- broadband couplers
- power splitters

This application note also highlights the features of the U2000 Series for SNA and compares its functionality with other test alternatives. It illustrates how the U2000 Series addresses transmission, reflection, simultaneous transmission and reflection, and power sweep measurements. The uncertainties of transmission and reflection measurement are also discussed.



Table of Contents

Overview	1
Comparing Test Equipment	3
Transmission Measurements	6
Transmission Measurement Uncertainties	10
Reflection Measurements	14
Reflection Measurement Uncertainty	17
Simultaneous Transmission and Reflection Measurements	22
Transmission and Reflection Measurement Uncertainty	25
Power Sweep Measurement	26
Optimizing Measurement Speed	27
Summary	28
Ordering Information	29
References	31
Related Agilent Literature	31
Appendix	32
Agilent Advantage Services	Back cover
Contact Agilent	Back cover

Comparing Test Equipment

There are many test instruments capable of performing stimulus-response measurements, including a USB sensor based scalar measurement setup, network analyzers, and spectrum analyzers with tracking generators.

Network analyzers

There are two types of network analyzers: vector or scalar. If phase information is required, a vector network analyzer (VNA) is required. A VNA makes the most accurate stimulus-response measurements by using vector error correction algorithms. Swept tuned spectrum analyzers, scalar network analyzers (SNA), and power meters are scalar instruments. Scalar network analyzers (like the discontinued Agilent 8757D) are the most popular instrument for measuring scalar stimulus-response. Features offered by the scalar network analyzer include:

- Wide frequency coverage from 10 MHz to 110 GHz (detector dependent)
- Fast sweep time of 40 to 400 ms per sweep
- Multiple input ports for making simultaneous transmission and reflection measurements without having to reconfigure or recalibrate the measurement setup
- Flexible display formats, selectable from the front panel and calculated inside the scalar network analyzer to allow visual analysis of the measured transmission and reflection parameters

USB sensor based SNAs

Comparatively, a USB sensor based SNA also has some attractive features. The USB sensor based SNA offers a wide power range of -60 to $+44$ dBm depending on the selected power sensor. It provides superior accuracy due to its fully calibrated sensor, which provides an absolute measurement accuracy of 3%. The frequency response uncertainty is minimized to within ± 0.1 dB and the calibration factor correction is stored inside the sensor's memory. Perhaps the most important feature is its dual use; apart from performing accurate power measurements, USB sensors can also be setup to perform accurate scalar power measurements with low overall setup cost.

When U2000 Series USB sensors are used together with a signal source, power splitter, and coupler, they can be transformed into a SNA to perform transmission gain or loss, and return loss measurements. Figure 1 shows a few different configurations of a U2000 Series sensor based SNA. Free demonstration software is available for download from Agilent's Web site for each of the setups shown in this application note. The demonstration software is compatible with all Agilent EPM, EPM-P, P-Series power meters, and USB sensors.

www.agilent.com/find/SNAsoftware_download

Comparing Test Equipment

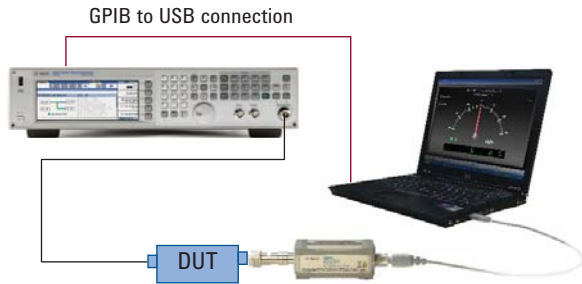

a. Unleveled gain measurement (non-ratioed)

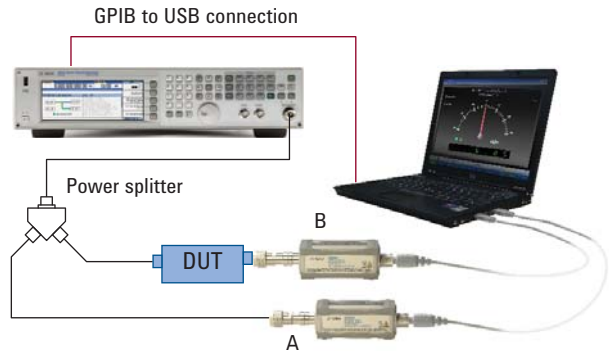

b. Leveled gain measurement (ratioed)

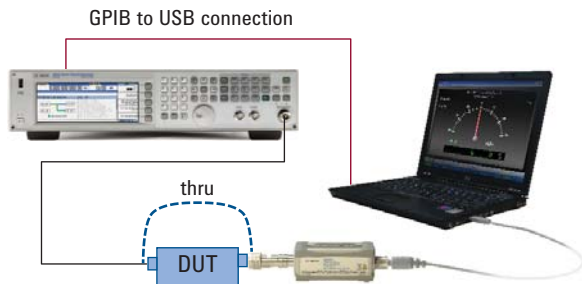

c. Post leveling gain measurement

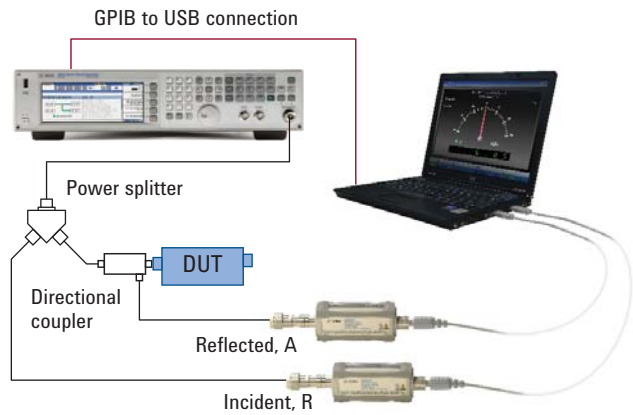

d. Return loss measurement

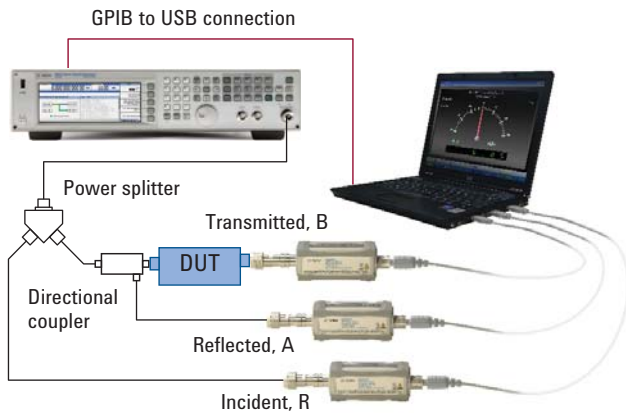

e. Transmission gain/loss and return loss measurements

Figure 1. The U2000 Series sensor based SNA can be used in a variety of configurations

Comparing Test Equipment

Prior to performing actual SNA measurements using a U2000 Series device, calibration is required in order to adjust the losses and mismatches due to the power splitter, coupler, cables and adapters. The following section discusses transmission power measurements and what calibrations are required.

Table 1 provides an overview comparing the different type of instrument capable of performing scalar network analysis, including the discontinued Agilent 8757D SNA and the next-generation U2000 series USB sensor based SNA.

Table 1. Test equipment options for stimulus-response measurements

	8757D, detector and 85027x directional bridge	U2000 Series sensor based SNA
Dynamic range	-60 to +16 dBm	-60 to +20 dBm (U2000A) -50 to +30 dBm (U2000H) -30 to +44 dBm (U2000B)
Frequency range	10 MHz to 110 GHz (detector-dependent)	9 kHz to 26.5 GHz (sensor dependent) (Frequency range up to 110 GHz is available with Agilent power meter and sensor combinations. Refer to 'Ordering Information' section for millimeter wave sensors)
Linearity	Not specified	3%
Directivity	40 dB to 20 GHz 36 dB to 26.5 GHz 30 dB to 40 GHz 25 dB to 50 GHz (bridge-dependent)	Coupler/bridge dependent Example: 86205A bridge 40 dB to 2 GHz 30 dB to 3 GHz 20 dB to 5 GHz 16 dB to 6 GHz
Transmission measurement accuracy	~0.5 to 2.3 dB ¹ (dynamic accuracy + mismatch uncertainty)	~0.3 to 0.5 dB (mismatch uncertainty + linearity)
Reflection measurement accuracy	Mainly depend on the directivity of the coupler/bridge	Mainly depend on the directivity of the coupler/bridge
Return loss of detector/sensor (typical) at 2 GHz 18 GHz	20 dB 20 dB	40 dB 26 dB
Frequency response uncertainty to 18 GHz	±0.35 dB for precision detector (up to ±2 dB for other detectors)	±0.1 dB
Measurement speed	40 to 400 ms per sweep (75 ms for 2 traces with 201 points)	~50 ms per reading (~10 second per sweep for 201 points) ²
Price	8757D (discontinued): \$21,000 Detector: \$1,800 to \$2,600 Total solution (18 GHz): ~\$67,000 (including source) ~\$35,000 (excluding source)	Total solution (18 GHz): ~\$40,000 (including source) ~\$14,000 (excluding source)

1. Extract from 8757D data sheet (literature number 5091-2471E).

2. Speed down to 15 ms per reading is available with Agilent P-Series power meters and sensors with external triggering sweep measurement capability. For details, please refer to "Optimizing Measurement Speed" section.

Transmission Measurements

What are transmission measurements?

A scalar transmission measurement determines the gain or loss of a DUT. Let's take a look at some of the commonly used terms for transmission measurements.

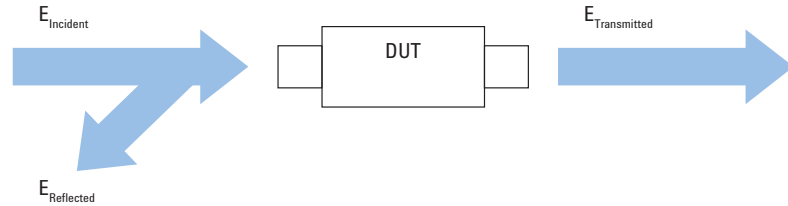

Figure 2. Common terms used in scalar network measurements

Terms used to define the transmission coefficient include:

Transmission coefficient (linear):

$$\tau = \frac{E_{Transmitted}}{E_{Incident}}$$

$$\begin{aligned} \text{Transmission gain/loss (dB)} &= 20 \log \tau \text{ (gain)} \\ &= -20 \log \tau \text{ (loss)} \\ &= 20 \log (E_{Transmitted}) - 20 \log (E_{Incident}) \end{aligned}$$

The transmission coefficient, τ , is equal to the transmitted voltage, $E_{Transmitted}$, divided by the incident voltage, $E_{Incident}$. Since many displays are logarithmic, transmission coefficient needs to be displayed in dB. This coefficient can be applied to different transmission measurements. Attenuation, insertion loss, and gain measurements can be expressed as follows:

$$\text{Attenuation or Insertion loss (dB)} = P_{incident} \text{ (dBm)} - P_{transmitted} \text{ (dBm)}$$

$$\text{Gain (dB)} = P_{transmitted} \text{ (dBm)} - P_{incident} \text{ (dBm)}$$

Where

$P_{incident}$ is incident power

$P_{transmitted}$ is transmitted power

Transmission Measurements

Making transmission measurement with U2000 Series sensor based SNA

There are a few methods of measuring transmission using the U2000 Series sensor based SNA:

1. Unleveled transmission measurement
2. Leveled transmission measurement
3. Post leveling transmission measurement

Unleveled transmission measurement

As its name implies, unleveled transmission measurements assume the output power from the signal source is accurate and that there is minimum cable loss from the source to the DUT (Figure 3). Thus the transmission coefficient can be calculated as:

$$\text{Sensor measured power} - \text{Signal source output power}$$

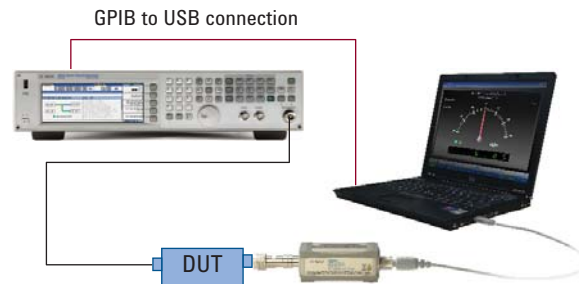

Figure 3. Unleveled transmission measurement

Leveled transmission measurement

Leveled transmission measurement uses a power splitter to split the source power between the DUT and Sensor A (Figure 4). With the equal tracking characteristic of a power splitter, the input power of the DUT is equal to the measured power of Sensor A. Thus the transmission coefficient can be calculated as:

$$(\text{Sensor_B_power}) - (\text{Sensor_A_power})$$

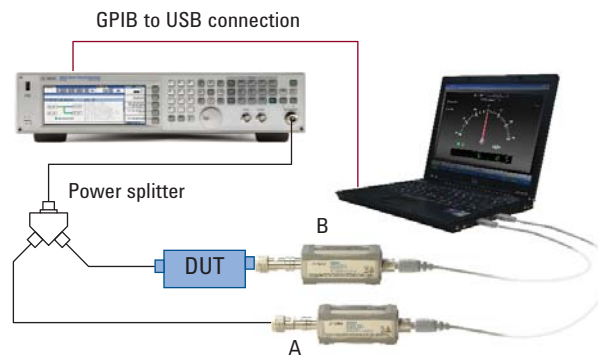

Figure 4. Leveled transmission measurement

Transmission Measurements

Post leveling measurement

Post leveling measurement is similar to unlevelled transmission measurement, but with an additional step for calibrating the path loss (Figure 5). In this configuration, the DUT is removed so that the sensor measures the output power from the source directly. This data is stored as the calibration factor over a range of frequencies. The DUT is then installed and another set of data is collected at its output. The transmission coefficient is calculated as:

$$\text{(Measured power – Calibration factor)}$$

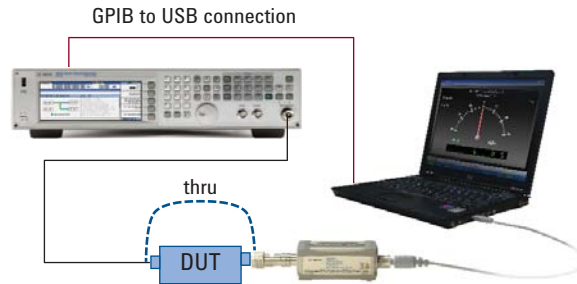

Figure 5. Post leveling measurement

Leveled transmission measurement

Leveled transmission measurement is performed as follows:

1. Configure the USB sensors as shown in Figure 6.
2. Use the software running on the PC to configure the 'start', 'stop', and 'step' frequencies; the power level for the source; and the average count for the sensor.
3. The transmission coefficient can be calculated as:

$$\text{Sensor_B_power – Sensor_A_power}$$

Where

Sensor_B_power is the transmitted power

Sensor_A_power is the incident power

4. For improved accuracy, increase the average count. However, doing so will slow down the measurement speed. Conversely, to increase the measurement speed, turning off the average count will lower accuracy.

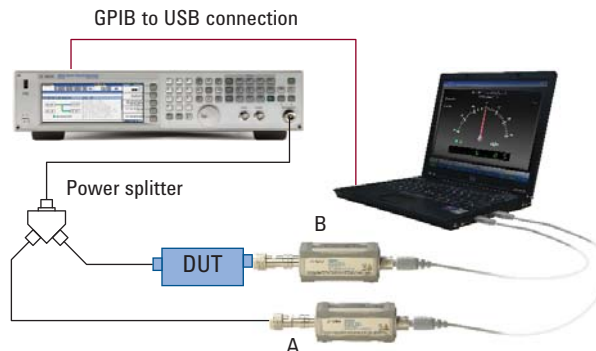

Figure 6. Leveled transmission measurement setup

Transmission Measurements

Figure 7 shows sample results for transmission measurements of a low pass filter using the U2000 Series sensor based SNA setup and demonstration software.

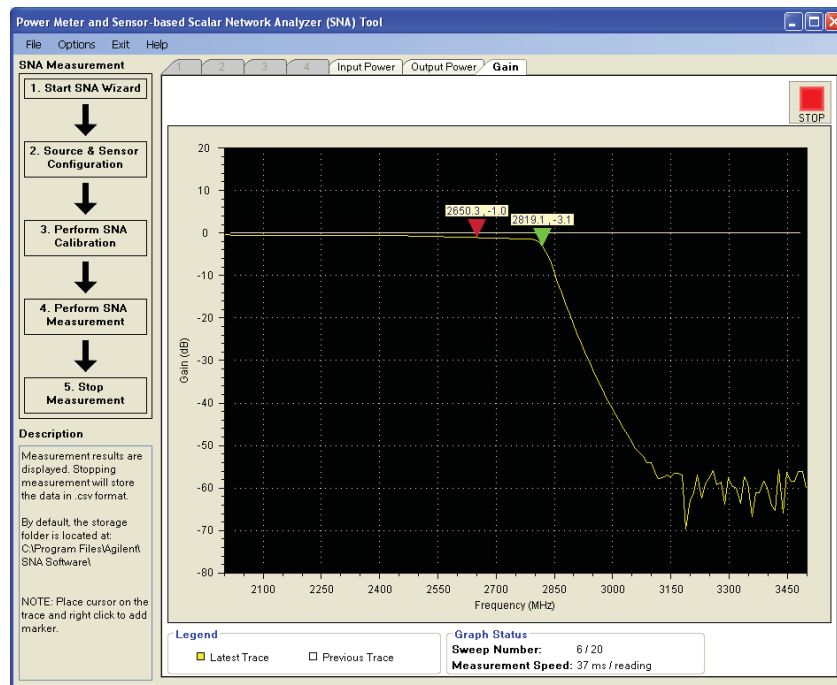

Figure 7. Transmission measurement of a low pass filter using U2000 series based SNA and demonstration software

Transmission Measurement Uncertainties

After the transmission measurement is made, the next step is to determine the accuracy of the measurement. The total uncertainty for a transmission measurement is a combination of frequency response, mismatch uncertainty during the calibration and measurement, and the linearity of the sensors. Source and sensor mismatch cause an uncertainty around both the calibration and measurement. Frequency response error is very minimum for the USB sensor based SNA since corrections are done through the sensor's calibration factors. Frequency response error can be further minimized through normalization or calibration prior to actual measurement.

The U2000 Series USB power sensor is a diode-based sensor that converts high frequency energy to DC by means of diode sensor rectification properties, which arise from its non-linear current-voltage characteristics. In the square-law region (below -20 dBm), the diode's detected output voltage is linearly proportional to the input power (V_{out} proportional to V_{in}^2), so power is measured directly. Above -20 dBm, the diode's transfer characteristic transitions towards a linear detection function (V_{out} proportional to V_{in}) and the square-law relationship is no longer valid. Linearity error refers to the amount of deviation from the ideal straight line relationship $P_{measured}$ to P_{in} (V_{out} to V_{in}^2 in the square-law region for the diode). A typical diode sensor will have a linearity of less than 3%.

A proper understanding of the source of mismatch errors can help to minimize the associated measurement uncertainty. Mismatch uncertainties can be broken into two categories: (1) uncertainties associated with the calibration stage of the measurement and (2) uncertainties associated with the measurement stage of the measurement.

Transmission Measurement Uncertainties

Mismatch uncertainties for calibration

Mismatch uncertainties for calibration are due to the impedance mismatch between the source and the sensor. A portion of the incident signal is reflected back towards the source because of the sensor's input match. This reflected signal is then re-reflected by the source impedance mismatch, resulting in an uncertainty vector related to the incident signal at some unknown phase. This uncertainty vector can add or subtract from the actual measured amplitude, causing an error in the calibration measurement.

For uncertainties associated with the calibration stage (Figure 8), when the sensor is connected to the source, the incident signal first encounters the sensor impedance, where part of the incident signal is reflected. This reflected signal is then re-reflected by the source mismatch, resulting in an uncertainty vector of $\rho_s \times \rho_d$ at some unknown phase relationship to the incident signal. The worst case of the signal seen by the sensor would be $1 \pm \rho_s \times \rho_d$.

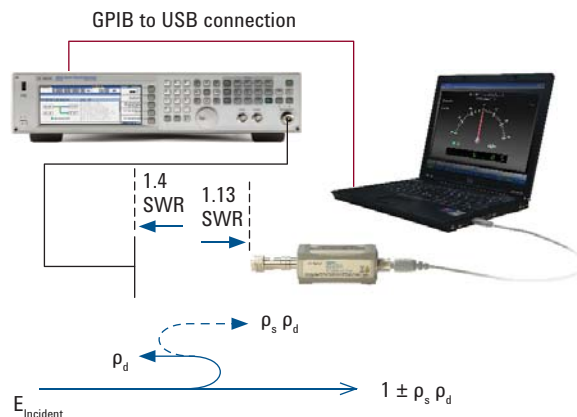

Figure 8. Mismatch uncertainties for calibration (post leveling transmission measurement)

Transmission Measurement Uncertainties

Mismatch uncertainties for measurement

Mismatch uncertainties during the measurement of the DUT are caused by the source/device input mismatch and device output/sensor mismatch (Figure 9). Uncertainties in the measurement stage are due to source/DUT input mismatch ($1 \pm \rho_s \times \rho_1$) and DUT output/sensor mismatch ($1 \pm \rho_d \times \rho_2$).

Because the transmission coefficient of the device is the difference between the calibration value and the measured value, the overall mismatch uncertainties are a combination of the mismatch during calibration and measurement.

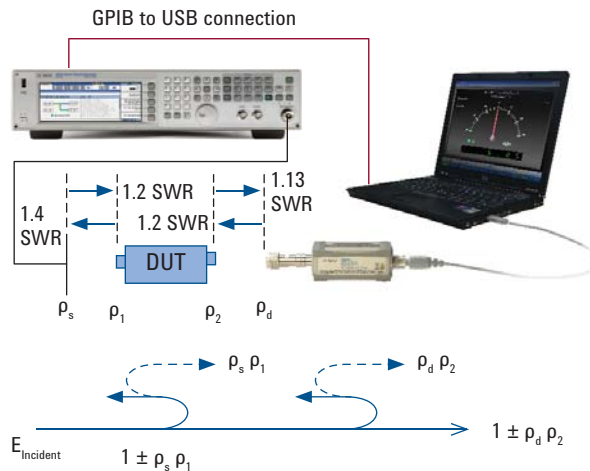

Figure 9. Mismatch uncertainties for measurement (post leveling transmission measurement)

Calculating transmission measurement errors

To get a feel for the errors associated with transmission measurement, let's calculate typical worst case uncertainties based on the post leveling transmission measurement previously described.

To calculate the mismatch errors, the standing wave ratio (SWR) needs to be converted to the reflection coefficient, ρ .

$$\rho = \frac{SWR - 1}{SWR + 1}$$

At 1 GHz, the MXG output SWR is 1.4 while the U2000A SWR is 1.13. Assuming the DUT input and output SWR is 1.2, the reflection coefficient can be calculated as:

$$\rho_s = 0.167; \rho_d = 0.061; \rho_1 = 0.091; \rho_2 = 0.091$$

Transmission Measurement Uncertainties

The U2000A's linearity is less than 3%. The worst case transmission measurement uncertainty can be calculated as:

$$\text{Transmission uncertainty} = \pm\{[\text{calibration mismatch uncertainties}] + [\text{measurement mismatch uncertainties}] + [2 \times \text{linearity}]\}$$

$$\begin{aligned} \text{Transmission uncertainty (dB)} &= [20 \log(1 \pm (\rho_s \times \rho_d))] + [20 \log(1 \pm (\rho_s \times \rho_1)) + \\ & 20 \log(1 \pm (\rho_d \times \rho_2)) + 2 \times 10 \log(1 \pm 3\%)] \\ &= 0.527 \text{ dB}, -0.530 \text{ dB} \end{aligned}$$

This is the worst case uncertainty for transmission measurement of a USB sensor based SNA. In this example, it is assumed that the DUT has an input-to-output isolation of better than 3 dB so that multiple reflections have a negligible effect on the uncertainty. For a low loss, bidirectional device, the term "20 log (1 ± ρ_s × ρ_d)" will be part of the measurement uncertainties and therefore will occur twice in the maximum mismatch error equation.

To further improve the transmission measurement uncertainties, the ratio technique can be used to improve the source match.

Source match can be improved by calculating the ratio of the incident and reflected signals (Figure 6). With this technique, any variation in the incident signal is being ratioed out. Any re-reflections are seen by both sensors and when the ratio of transmission/reflected signal is obtained, the effect of source match is cancelled. A power splitter is a good choice for ratio technique due to its small size and broadband response. The source match in this case will be replaced by the output match of the power splitter.

At 1 GHz, a power splitter output SWR is 1.10 (ρ_s' = 0.0476). The transmission measurement uncertainty can be improved to:

$$\begin{aligned} \text{Transmission uncertainty (dB)} &= [20 \log(1 \pm \rho_s \times \rho_d)] + [20 \log(1 \pm \rho_s \times \rho_1) + \\ & 20 \log(1 \pm \rho_d \times \rho_2) + 2 \times 10 \log(1 \pm 3\%)] \\ &= 0.371 \text{ dB}, -0.371 \text{ dB} \end{aligned}$$

With ratio technique, the transmission uncertainty has been improved from around ±0.53 to ±0.37 dB. This is the worst case uncertainty for transmission measurement.

An attenuation pad is frequently used to improve the mismatch between the detector of SNA and DUT. The attenuator pad is used because of the poor input match of the detector. U2000 Series USB power sensors have good input match thus the addition of attenuation pad is typically not required.

Reflection Measurements

What are reflection measurements?

A scalar reflection measurement is concerned with how efficiently energy is transferred to a DUT (Figure 10). It is a measure of the amount of mismatch between a DUT and a Z_o transmission line (Z_o = characteristic impedance, typically 50 Ω). Not all the energy incident upon a device is absorbed by the device, and the portion not absorbed is reflected back towards the source. The efficiency of energy transfer can be determined by comparing the incident and reflected signals.

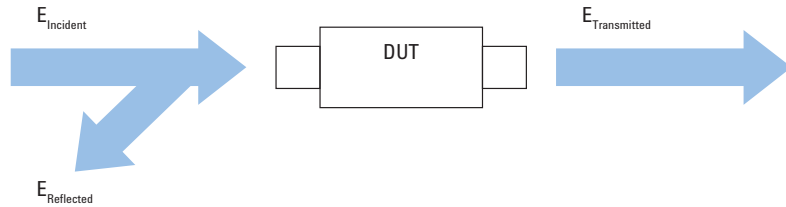

Figure 10. Overview of scalar reflection measurement concept

The reflection coefficient, ρ , is equal to the ratio of reflected voltage wave, $E_{\text{Reflected}}$, to the incident voltage wave, E_{Incident} . For a transmission line of characteristic impedance, Z_o , terminated with a perfectly matched load, all the energy is transferred to the load and none is reflected: $E_{\text{Reflected}} = 0$ then $\rho = 0$. When the same transmission line is terminated with an open or short circuit, all the energy is reflected back: $E_{\text{Reflected}} = E_{\text{Incident}}$ then $\rho = 1$. Therefore, the possible values for ρ are 0 to 1.

$$\text{Reflection coefficient, } \rho = \frac{E_{\text{Reflection}}}{E_{\text{Incident}}}$$

Since many displays are logarithmic, a term to express the reflected coefficient in dB is needed. Return loss is the logarithmic expression of the relationship between the reflected signal and the incident signal. Return loss can be calculated as $-20 \log \rho$. Thus the range of values for return loss is infinity (for a matched load) to 0 (for an open or short circuit).

$$\text{Return loss} = -20 \log \rho$$

Another term commonly used is standing-wave-ratio (SWR). Standing waves are caused by the interaction of the incident and reflected waves along a transmission line. The SWR equals the maximum envelope voltage of the combined travelling waves over the minimum envelope voltage. SWR can also be calculated from the reflection coefficient: $\text{SWR} = (1 + \rho)/(1 - \rho)$ and ranges from 1 (for a matched load) to infinity (open or short circuit).

$$\text{SWR} = \frac{1 + \rho}{1 - \rho}$$

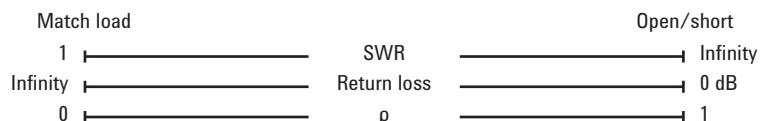

Figure 11. Reflection measurement relationships between matched load and open/short circuit

Reflection Measurements

Directional coupler or bridge

Before we discuss reflection measurements in detail, let's try to understand more about signal separation devices, such as a coupler or a bridge, which are crucial for accurate reflection measurements (Figure 12 and Figure 13).



Figure 12. Agilent 86205A and 86207A directional bridge

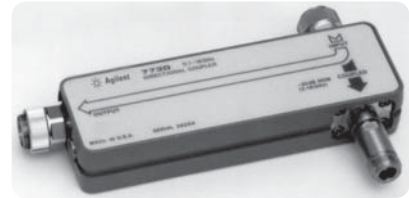

Figure 13. Agilent 773D directional coupler

A directional coupler, or bridge, will couple a portion of the signal flowing through the main arm to the auxiliary arm. The coupling factor is the relationship between the coupled path, or the auxiliary arm, to the through-path or main arm, expressed in dB. If the coupler is turned around and the signal is allowed to flow in the reverse direction through the coupler, ideally there will be no power in the auxiliary arm. However, some energy will leak through the coupler. A measure of this leakage signal is defined as isolation of the coupler.

Another term frequently associated with couplers is directivity. Directivity is the ability of the coupler to separate signals flowing in the opposite directions. Directivity is defined as the ratio of power measured in the auxiliary arm with a coupler connected in the forward direction, to the power measured in the auxiliary arm with a coupler connected in the reverse direction. In both cases, the coupler output will have to be terminated with a Z_0 load with the same input power level being applied:

$$\text{Directivity} = \frac{\text{Coupling factor}}{\text{Isolation}}$$

$$\text{Directivity (in dB)} = \text{Isolation (dB)} - \text{Coupling factor (dB)}$$

Where

$$\text{Coupling factor (dB)} = -10 \log \left[\frac{P(\text{coupling factor, forward direction})}{P(\text{in})} \right]$$

$$\text{Isolation (dB)} = -10 \log \left[\frac{P(\text{coupling factor, reverse direction})}{P(\text{in})} \right]$$

$$\text{Linear term directivity} = 10^{\frac{-\text{Directivity (dB)}}{20}}$$

The sources of imperfect directivity are leakages, internal coupler load reflections, and connector reflections.

In general, a broadband coupler has insertion loss in the order of 1 dB. On the other hand, a directional bridge has insertion loss of at least 6 dB. This loss will directly subtract from the dynamic range of the measurements.

Reflection Measurements

Making reflection measurements with an Agilent U2000 Series sensor based SNA

Before making a reflection measurement the USB sensor/signal generator must be configured as shown in Figure 14. For reflection measurement, a signal separation device such as power splitter, directional coupler, or bridge must be added (Figure 15).

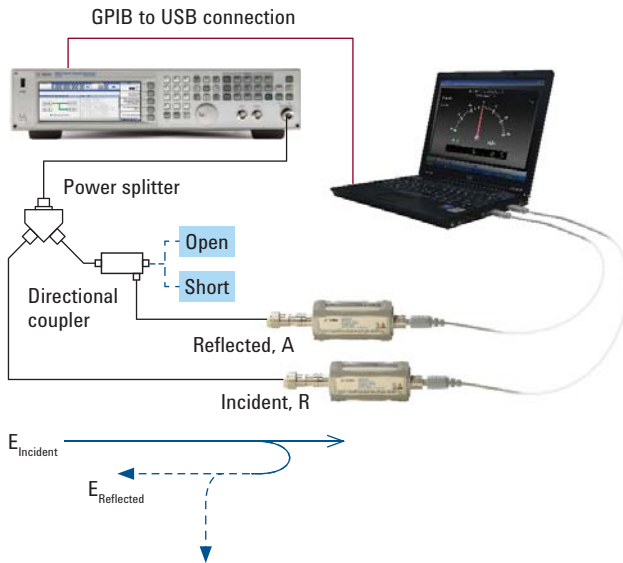

Figure 14. Calibration setup prior to reflection measurement

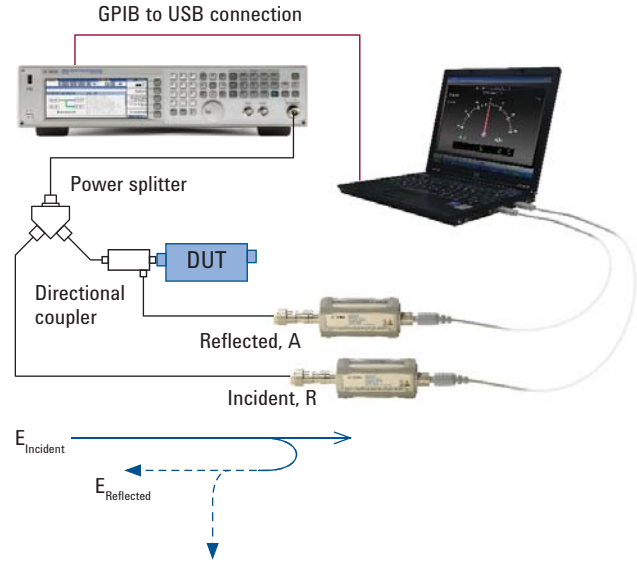

Figure 15. Reflection measurement setup

The power splitter is used to couple a portion of the incident signal for incident power measurement while the coupler is used to couple the reflected signal for reflected power measurement. The DUT is connected at the output of the coupler.

The steps required to make accurate reflected measurement are:

1. Setup the instruments as shown in Figure 14.
2. Configure the signal source and power sensor settings such as frequency range, power level, and number of averages.
3. Perform open-short calibration to establish a zero dB return loss and store the calibration data into PC. The calibration data is the average of the open and short calibration.
4. Connect the DUT as shown in Figure 15 and make reflection measurement.
5. Normalized the measurement results by subtracting the calibration data from the measurement data.

For Step 2, it is important that once the settings have been adjusted, they should not be changed during the course of measurement. If any settings are changed, inaccuracies could be introduced into the measurement system that might not otherwise be present.

For Step 3, the open-short calibration is intended to remove calibration error due to the sum of directivity and source match.

Reflection Measurement Uncertainty

Now that the reflection measurement has been made, the accuracy of the measurement must be determined. The measurement uncertainty associated with reflection measurement is comprised of three terms:

$$\Delta\rho = A + B\rho + C\rho^2$$

This equation is a simplification of a complex flow-graph analysis. $\Delta\rho$ is the worst case uncertainty for the reflection measurement where ρ is the measured reflection coefficient of the device. A, B, and C are linear terms and an explanation of each term follows.

Term A: Directivity

Directivity is the ability of the bridge or coupler to separate signals flowing in opposite directions. Since no signal separation device is perfect, some of the incident energy flowing in the main arm of the coupler may leak across the auxiliary arm, causing an error in the signal level measured by the sensor. This directivity signal is independent of the reflection coefficient of the DUT and adds (worst case) directly to the total uncertainty. If the signal reflected from the DUT is large, for example for a short circuit, then the directivity will be small compared to the reflected signal. The effect of directivity will be insignificant. If the signal reflected from the DUT is small (high return loss), then the directivity signal will be significant compare to the reflected signal. Thus the uncertainty due to directivity will be significant in this case (Figure 16). Therefore, the signal separation device selected is extremely important to the accuracy of the reflection measurement. A recommended bridge is the Agilent 86205A which has directivity of up to 40 dB. Since the impact of directivity cannot be removed, it is important to select a separation device with high enough directivity.

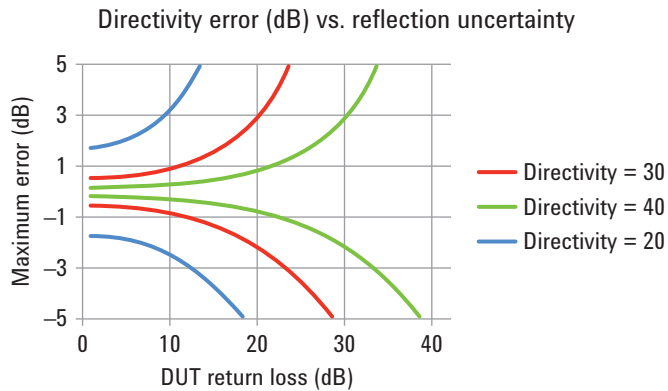

Figure 16. Effect of coupler directivity to the reflection measurement uncertainty

Reflection Measurement Uncertainty

Term B: Calibration error

When calibrating the system with a standard (open or short), some error terms will also be measured. Directivity and source match are the error terms that always present and will be measured. If it is assumed that no other errors are present, then the best case calibration error (B) is equal to the sum of directivity and source match:

$$B = A + C$$

Figure 17 shows the frequency response of an open standard. Notice the ripple caused by source match and directivity error vectors. Another standard, short circuit, could also be used as a calibration standard. Notice that the ripple is still present, but the phase is different (Figure 18). The calibration error due to the sum of the directivity and source match errors can be removed by averaging the short and open circuit responses. Though the reflection from an open circuit is 180 degrees out of phase compared to a short circuit, the errors due to the sum of directivity and source match do not change phase when the load is changed from an open to a short. Thus open/short average then averages out calibration error thus making $B = 0$. Figure 18 shows the open/short average. Notice that the ripples are removed.

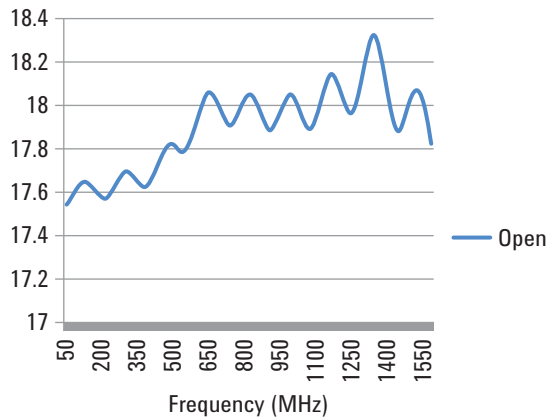

Figure 17. Frequency response of an open standard

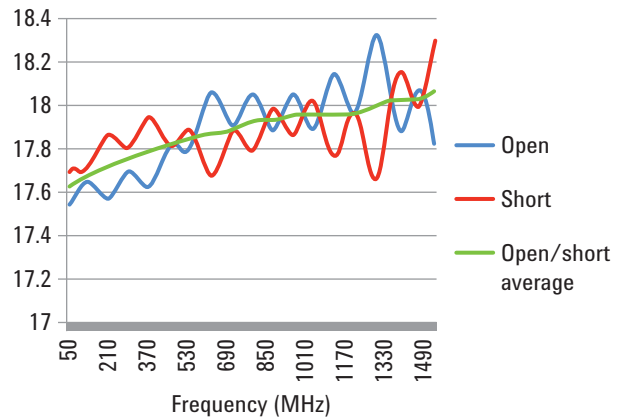

Figure 18. Frequency response of a short standard (red) and open/short average (green)

Open/short average could be calculated as:

$$\text{Open/short average} = \frac{C_{open} + C_{short}}{2}$$

Where

C_{open} is the linear term reflection coefficient for an open standard

C_{short} is the linear term reflection coefficient for a short standard

$$\text{Open/short average (in dB)} = 20 \log \left(\frac{10^{\frac{-C_{open(dB)}}{20}} + 10^{\frac{-C_{short(dB)}}{20}}}{2} \right)$$

Where

$C_{open(dB)}$ is the reflection coefficient in dB for an open standard

$C_{short(dB)}$ is the reflection coefficient in dB for a short standard

Reflection Measurement Uncertainty

Term C: Effective source match

A perfect source match would deliver a constant power to the load regardless of the reflection from the load. If the source match is not perfect, signals will be re-reflected, adding to the incident signal at some unknown phase, and causing an error in the measurement. Figure 19 shows that the first reflection from the DUT is ρ_L . This is the signal to measure (reflection coefficient of the DUT). This signal flows towards the source, where it is re-reflected if the source match is not perfect. This results in a signal $\rho_L \rho_s$ flowing back toward the DUT where it is again re-reflected and sampled as $\rho_L^2 \rho_s$. When the reflected signal, ρ_L , is large (low return loss), source match will cause a significant error. If ρ_L is small, then the effect of source match is insignificant (Figure 20). Recall that this is directly opposite with the effect of directivity, whereby directivity effect is significant for high return loss and less significant for low return loss.

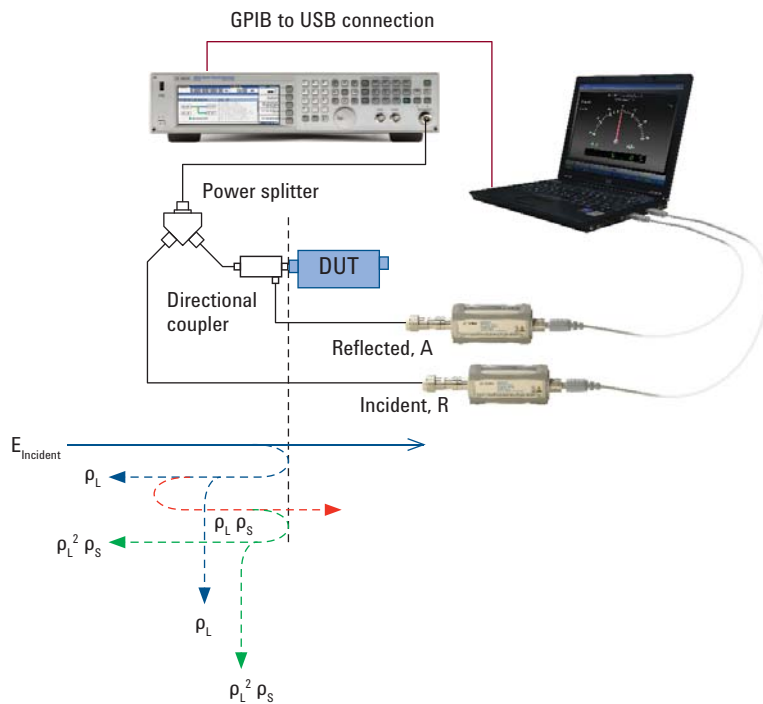

Figure 19. Ratio measurement technique is used to improve source match

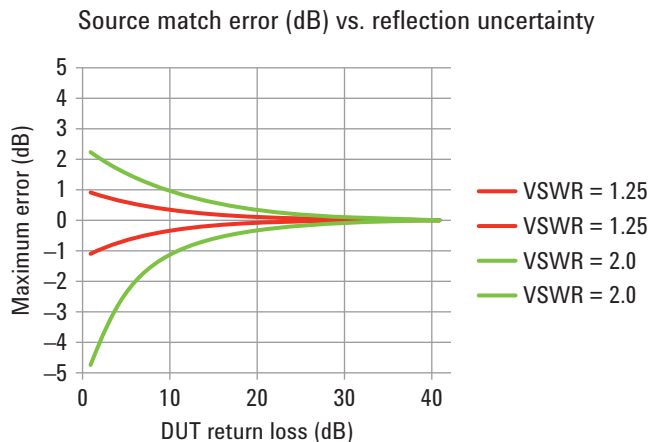

Figure 20. Effect of source match to the reflection measurement uncertainty

Reflection Measurement Uncertainty

Effective source match can be improved by ratioing the incident and reflected signals using a 2-resistor power splitter. Any reflected signals are seen by both the sensors and when the ratio of reflected signal over incident signal is taken, the effect of source match is cancelled. Again since the splitter is not perfect, the effective source match must be determined. It can be found in the power splitter selection guide, *Agilent RF and Microwave Test Accessories*, publication number 5990-5499EN. For the Agilent 11667A power splitter, the effective source match is < 1.10 at below 4 GHz, < 1.20 for below 8 GHz, and < 1.33 for below 18 GHz.

We have discussed three ways to improve the accuracy of reflection measurements:

1. A high directivity coupler or bridge helps to reduce the A term (directivity error) for accurate measurement of low reflection device.
2. Using an open/short average removes the B term (calibration error) from the uncertainty equation.
3. The source match improvement can be done through a ratio technique to reduce the C term (effective source match) of the uncertainty equation.

Accuracy impact examples

The following examples show how these methods impact the accuracy of reflection measurements.

Example 1:

Reflection measurement of a device with return loss of 12 dB ($\rho = 0.2512$), with only simple open calibration.

$$\begin{aligned}\text{Coupler directivity} &= 30 \text{ dB (0.0316)} \\ \text{Source match} &= 1.4:1 (\rho_s = 0.1667) \\ \Delta\rho &= A + B\rho + C\rho^2 \\ &= 0.0316 + (0.03162 + 0.1667) \times 0.2512 + 0.1667 \times (0.2512)^2 \\ &= 0.0316 + 0.0498 + 0.0105 \\ &= 0.0919\end{aligned}$$

The worst case reflection uncertainty for the device with a ρ of 0.2512 is ± 0.0919 . This can be converted to dB with $-20 \times \log(0.2512 \pm 0.0919) = 9.3 \text{ dB}$ and 16.0 dB. The error in dB is -2.7 dB and 4.0 dB. This is a significant error.

Example 2:

The accuracy can be improved by carrying out open/short average calibration to remove the B term. Using the same set of equipment:

$$\begin{aligned}\Delta\rho &= A + B\rho + C\rho^2 \\ &= 0.0316 + 0 + 0.1667 \times (0.2512)^2 \\ &= 0.0316 + 0.0105 \\ &= 0.0421\end{aligned}$$

The error in dB is -1.3 dB and 1.6 dB; an improvement in the accuracy of reflection measurement.

Reflection Measurement Uncertainty

Example 3:

Ratio technique with a power splitter can further improve the accuracy. Source match can be improved from 1.4 to 1.10 with the use of power splitter:

$$\begin{aligned}\Delta\rho &= A + B\rho + C\rho^2 \\ &= 0.0316 + 0 + 0.0476 \times (0.2512)^2 \\ &= 0.0346\end{aligned}$$

The error is now improved to -1.1 dB and 1.3 dB.

Example 4:

A good directivity coupler can be used to further improve the accuracy. Below is the improvement for a coupler with 40 dB of directivity:

$$\begin{aligned}\Delta\rho &= A + B\rho + C\rho^2 \\ &= 0.01 + 0 + 0.0476 \times (0.2512)^2 \\ &= 0.013\end{aligned}$$

The error is now improved to -0.44 dB and 0.46 dB, a significant improvement compared to 4 dB of error in Example 1.

Steps for accurate reflection measurement

In summary, to make an accurate reflection measurement using USB sensor based SNA, perform the following steps:

1. Setup the measurement using the ratio technique with power splitter and directional coupler or bridge.
2. Choose a coupler or bridge with good directivity (e.g. Agilent 86205A.)
3. Setup the frequency range, power level, and average count.
4. Perform open/short average calibration. Do not change settings after calibration.
5. Make measurement by connecting the DUT.
6. Normalized the measurement results by subtracting the calibration data from the measurement data.

Simultaneous Transmission and Reflection Measurements

It is possible to setup three U2000 Series USB sensors for simultaneous transmission and reflection measurements. Figure 21 and Figure 22 show the calibration and measurement configurations.

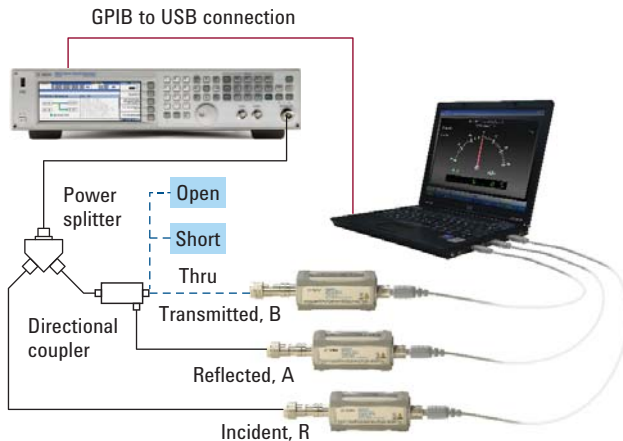

Figure 21. Calibration setup for simultaneous gain and return loss measurements

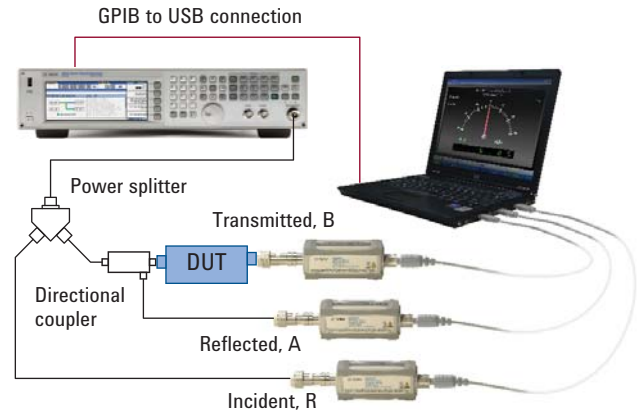

Figure 22. Measurement setup for simultaneous gain and return loss measurements

The power splitter is used to couple a portion of the incident signal for measurement while the coupler is used to couple the reflected signal for measurement. The DUT is connected to the output of the coupler. Output of the DUT is connected to another sensor for transmitted power measurement. Prior to the measurement, user is required to perform open, short, and thru calibration. Open/short calibration is required for an accurate reflection measurement as explained previously. Thru calibration is required for accurate transmission measurement to compensate for path loss.

The steps required to make accurate transmission and reflected measurement are:

1. Setup the instruments as shown in Figure 21.
2. Configure the signal source and power sensor settings such as frequency range, power level, and number of averages.
3. Perform open-short calibration to establish a zero dB return loss and store the open/short calibration data on a PC. The calibration data is the average of the open and short calibration.
4. Perform thru calibration to establish a zero dB transmission measurement and store thru calibration data on a PC.
5. Connect the DUT as in Figure 22 and make simultaneous transmission and reflection measurements.
6. Normalized the measurement results by subtracting the calibration data from the measurement data. Subtract open/short calibration data from reflection measurement and subtract thru calibration data from the transmission measurement.

Simultaneous Transmission and Reflection Measurements

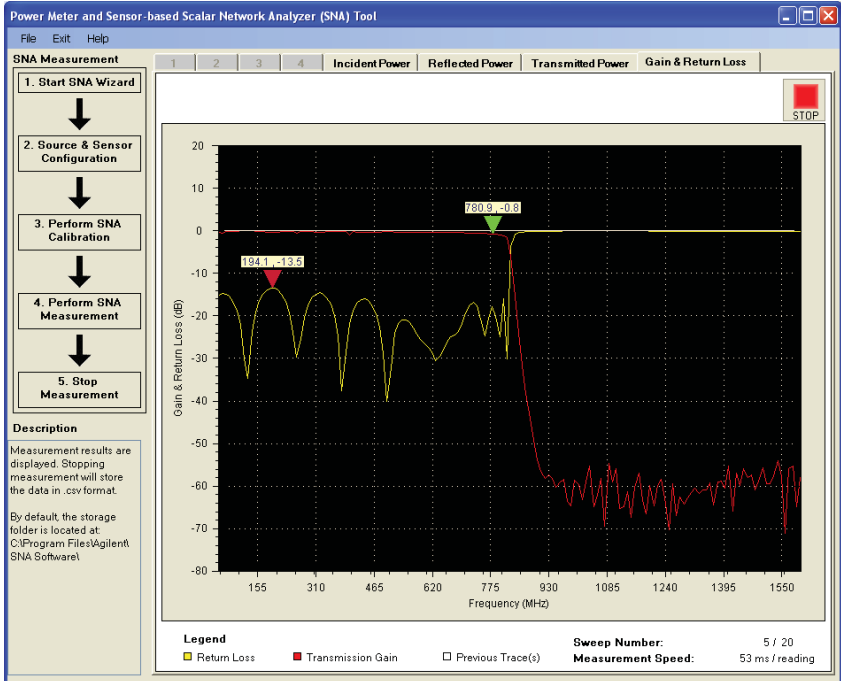

Figure 23. Simultaneous transmission and reflection measurements of a low pass filter using U2000 Series based SNA and demonstration software

Figure 23 shows simultaneous transmission and reflection measurements of a low pass filter using U2000 Series based SNA and demonstration software. Figures 24 and 25 show a comparison of the transmission and reflection measurement using a low pass filter using the U2000 Series based SNA versus an 8757D. The measurement results are very similar for these two different setups. Note that the delta at around 600 MHz is due to directivity error of the coupler used. Improvement can be made by using a coupler with better directivity. The results also show that a USB sensor based SNA provides better noise performance.

Simultaneous Transmission and Reflection Measurements

8757D and USB sensor based SNA measurement comparison of a low pass filter

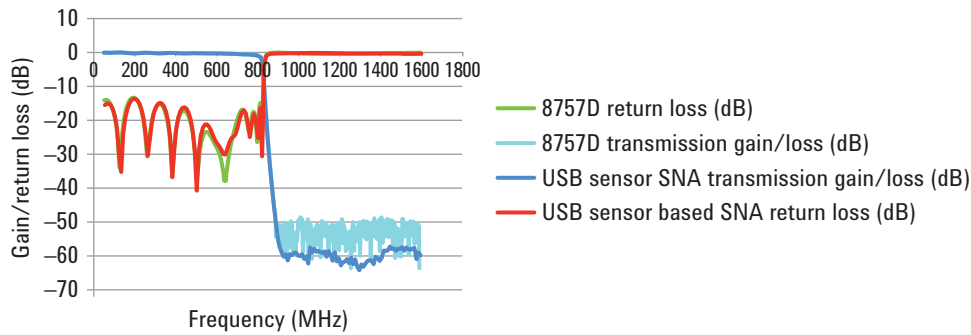

Figure 24. Low pass filter measurement comparison of 8757D and USB sensor based SNA

8757D and USB sensor based SNA measurement comparison of a low pass filter

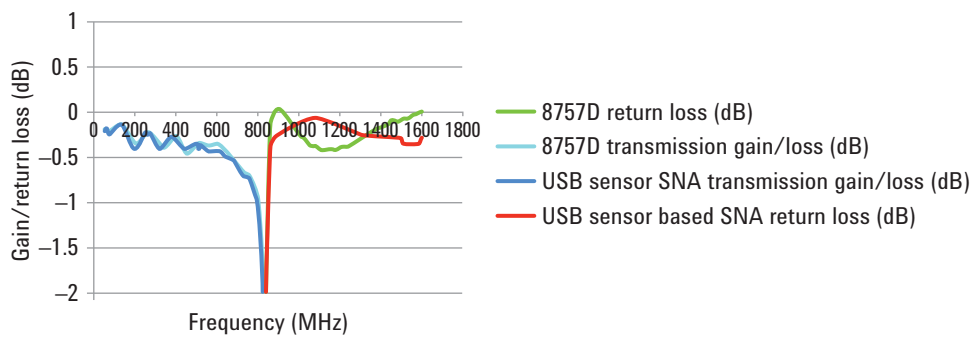

Figure 25. Low pass filter measurement comparison of 8757D and USB sensor based SNA (zoomed into 0 dB level in order to view transmission measurement accuracy)

Transmission and Reflection Measurement Uncertainty

Determining the uncertainty for the simultaneous transmission and reflection measurement is similar to the method explained previously.

Example 1:

At 1 GHz, U2000A SWR is 1.13. Assuming the DUT input and output SWR is 1.2 and the coupler source match is 1.4, the reflection coefficient can be calculated as:

$$\rho_s = 0.167; \rho_d = 0.061; \rho_1 = 0.091; \rho_2 = 0.091$$

The maximum mismatch error (MME) can be calculated as:

$$\begin{aligned} \text{MME} &= \pm\{[\text{calibration uncertainties}] + [\text{measurement uncertainties}]\} \\ \text{MME (dB)} &= [20 \log (1 \pm \rho_s \times \rho_d)] + [20 \log (1 \pm \rho_s \times \rho_1) + 20 \log (1 \pm \rho_d \times \rho_2)] \\ &= 0.27 \text{ dB}, -0.27 \text{ dB} \end{aligned}$$

Example 2:

To improve the mismatch error, a 10 dB pad can be connected between the coupler and DUT to improve the source match. Assume the use of a 10 dB pad with SWR of 1.1 ($\rho = 0.048$):

$$\text{Source match with 10 dB pad, } \rho_s' = 0.167(0.3162) + 0.048 = 0.065$$

The maximum mismatch error can be improved to:

$$\begin{aligned} \text{MME (dB)} &= [20 \log (1 \pm \rho_s' \times \rho_d)] + [20 \log (1 \pm \rho_s' \times \rho_1) + 20 \log (1 \pm \rho_d \times \rho_2)] \\ &= 0.13 \text{ dB}, -0.13 \text{ dB} \end{aligned}$$

Example 3:

Looking at the reflection measurement uncertainty of the same DUT with input SWR of 1.2 ($\rho = 0.091$, return loss = 20.8 dB), with open/short average calibration:

$$\begin{aligned} \text{Coupler directivity} &= 30 \text{ dB (0.0316)} \\ \text{Source match} &= 1.4:1 (\rho_s = 0.167) \\ \Delta\rho &= A + B\rho + C\rho^2 \\ &= 0.0316 + 0 + 0.167(0.091)^2 \\ &= 0.0316 + 0.0014 \\ &= 0.033 \end{aligned}$$

The worst case reflection uncertainty for the device with a ρ of 0.2512 is ± 0.0421 . This can be converted to dB with $-20 \cdot \log(0.091 \pm 0.033) = 18.1 \text{ dB}$ and 24.7 dB . The error in dB is -2.7 dB and 3.9 dB . This is a significant error.

Transmission and Reflection Measurement Uncertainty

Example 4:

Ratio technique with a power splitter can further improve the accuracy. Source match can be improved from 1.4 to 1.10 ($\rho = 0.0476$) with the use of power splitter:

$$\begin{aligned}\Delta\rho &= A + B\rho + C\rho^2 \\ &= 0.0316 + 0 + 0.0476(0.091)^2 \\ &= 0.032\end{aligned}$$

The error is now improved slightly to -2.6 dB and 3.8 dB. There is no much improvement as when the DUT reflection coefficient is small; the effect of source match is insignificant. A better way to improve the reflection uncertainty is to improve the error due to directivity. Directivity effect is significant for a DUT with a low reflection coefficient and less significant for a DUT with a high reflection coefficient.

Example 5:

For this example, a good directivity coupler is a better way to improve the accuracy. Below is the improvement for a coupler with 40 dB of directivity:

$$\begin{aligned}\Delta\rho &= A + B\rho + C\rho^2 \\ &= 0.01 + 0 + 0.0476(0.091)^2 \\ &= 0.010\end{aligned}$$

The worst case reflection uncertainty is now improved to -0.9 dB and 1.1 dB.

Power Sweep Measurement

It is possible to sweep the output power of the signal source and use the power sensor as a receiver to perform gain compression measurements. A power sweep measurement can be made over a fixed frequency. The available power range depends on the output power range of the signal source and the dynamic range of the power sensor. An ESG signal generator supports the range of -136 to $+17$ dBm while the USB sensor supports an 80 dB wide dynamic range from -60 to $+44$ dBm (sensor dependent).

Optimizing Measurement Speed

For applications that require fast measurement speed, it is possible to achieve 15 ms per reading using P-Series power meters and sensors with external triggering power or frequency sweep capability. This feature allows the signal source to trigger the power meter via an external TTL signal for measurement capture. After measurement is captured, the power meter outputs a trigger signal to the signal source to continue with the next step point. This sequence is repeated for every step point. The two way communication via hardwire connections between these two instruments helps to reduce communication overhead between these two instruments, resulting in overall test time improvement.

Figure 26 illustrates the configuration for this test setup. Please refer to Agilent application note “*Maximizing Measurement Speed Using P-Series Power Meters*” (literature number 5989-7678EN) for more details on how to enable this feature. The demonstration software also provides step-by-step instructions on how to setup this measurement.

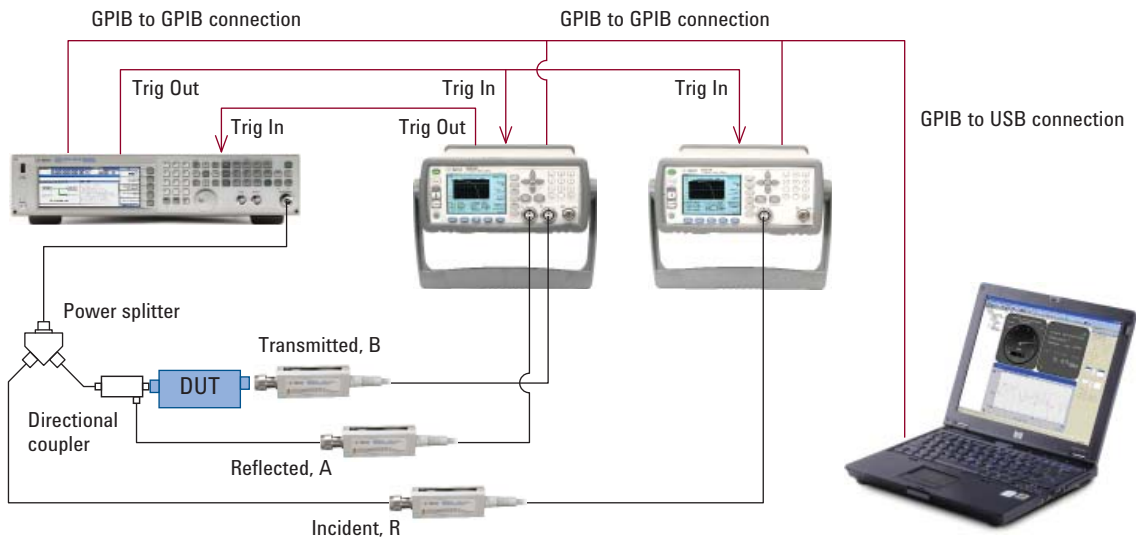

Figure 26. Fast scalar network analysis using Agilent P-Series power meters and sensors

Summary

The U2000 Series sensor based scalar network analyzer offers the ability to perform accurate transmission and reflection measurements in addition to general purpose power measurements. The USB sensor offers wide dynamic range and provides accuracy up to 3%. The frequency response is less than 0.1 dB with calibration factor corrections. When used together with a power splitter and coupler, it enables accurate scalar power measurements with low overall setup cost.

Transmission measurements such as 3 dB bandwidth of a bandpass filter, gain, and return loss of an amplifier, return loss of an antenna, flatness of a low pass filter, and frequency response of a cable can be easily made with the U2000 Series based SNA with the help of a simple software.

Ordering Information

Agilent power meters

N1913A/14A EPM Series power meters

E4416A/17A EPM-P Series power meters

N1911A/12A P-Series power meters

U2000 Series USB power sensors

Agilent power sensors

		POWER METERS			Product Description / Sensor Tech.	Frequency Range	Power Range	
		E4416/17A	N1913/14A	N1911/12A N8262A				
POWER SENSORS	N8480 / 8480 Series Thermocouple and Diode sensors	N848xA	✓	✓	✓	Thermocouple Power Sensor	100 kHz to 67 GHz	-35 dBm (316 μW) to +20 dBm (100 mW)
		N848xB/H	✓	✓	✓	High Power Thermocouple Sensor	100 kHz to 18 GHz	-15 dBm (100 μW) to +44 dBm (25 W)
		848xD	✓	✓	✓	Diode Power Sensor	100 kHz to 50 GHz	-70 dBm (100 pW) to -20 dBm (10 μW)
	CW sensors	E441xA	✓	✓	✓	Diode Power Sensor	10 MHz to 33 GHz	-70 dBm (100 pW) to +20 dBm (100 mW)
	E9300 Series average sensors	E930xA	✓	✓	✓	Diode Power Sensor	9 kHz to 24 GHz	-60 dBm (1 nW) to +20 dBm (100 mW)
		E930xB/H	✓	✓	✓	Diode Power Sensor	10 MHz to 18 GHz	-50 dBm (10 nW) to +44 dBm (25 W)
	E9320 Series peak and average sensors	E932xA	✓	-	✓	Diode Power Sensor	50 MHz to 18 GHz	-60 dBm (1 nW) to +20 dBm (100 mW)
		P-Series wideband sensors	N1921A	-	-	✓	Diode Power Sensor	50 MHz to 18 GHz
	N1922A		-	-	✓	Diode Power Sensor	50 MHz to 40 GHz	-35 dBm (316 nW) to +20 dBm (100 mW)
	U2000 USB sensors	U200xA	-	✓	-	Diode Power Sensor	9 kHz to 26.5 GHz	-60 dBm (1 nW) to +20 dBm (100 mW)
		U200xB	-	✓	-	Diode Power Sensor	10 MHz to 18 GHz	-30 dBm (1 μW) to +44 dBm (25 W)
		U200xH	-	✓	-	Diode Power Sensor	10 MHz to 24 GHz	-50 dBm (10 nW) to +44 dBm (25 W)
	8480 waveguide sensors	R8486D	✓	✓	✓	Waveguide Power Sensor	26.5 GHz to 40 GHz	-70 dBm (100 pW) to -20 dBm (10 μW)
		Q8486D	✓	✓	✓	Waveguide Power Sensor	33 GHz to 50 GHz	-70 dBm (100 pW) to -20 dBm (10 μW)
		N8486AR	✓	✓	✓	Thermocouple Waveguide Power Sensor	26.5 GHz to 40 GHz	-35 dBm (316 μW) to +20 dBm (100 mW)
		N8486AQ	✓	✓	✓	Thermocouple Waveguide Power Sensor	33 GHz to 50 GHz	-35 dBm (316 μW) to +20 dBm (100 mW)
		V8486A	✓	✓	✓	V-band Power Sensor	50 GHz to 75 GHz	-30 dBm (1 μW) to +20 dBm (100 mW)
		W8486A	✓	✓	✓	Waveguide Power Sensor	75 GHz to 110 GHz	-30 dBm (1 μW) to +20 dBm (100 mW)

Ordering Information

Agilent power splitters

11667A DC to 18 GHz power splitter

11667B DC to 26.5 GHz power splitter

11667C DC to 50 GHz power splitter

Agilent signal generators

Agilent ESG, MXG and PSG signal generators

Agilent couplers and bridges

Model	Frequency range	Directivity	Nominal coupling	Insertion loss
86205A	300 kHz to 6 GHz	< 30 dB to 5 MHz < 40 dB to 2 GHz < 30 dB to 3 GHz < 20 dB to 5 GHz < 16 dB to 6 GHz	16 dB	< 1.5 dB
86207A	300 kHz to 3 GHz	< 30 dB to 5 MHz < 40 dB to 1.3 GHz < 35 dB to 2 GHz < 30 dB to 3 GHz	15 dB	< 1.5 dB
87300B	1 to 20 GHz	> 16 dB	10 ± 0.5 dB	< 1.5 dB
87300C	1 to 26.5 GHz	> 14 dB to 12.4 GHz > 12 dB to 26.5 GHz	10 ± 1.0 dB	< 1.2 dB to 12.4 GHz < 1.7 dB to 26.5 GHz
87300D	6 to 26.5 GHz	> 13 dB	10 ± 0.5 dB	< 1.3 dB
87301B	10 to 46 GHz	> 10 dB	10 ± 0.7 dB	< 1.9 dB
87301C	10 to 50 GHz	> 10 dB	10 ± 0.7 dB	< 1.9 dB
87301D	1 to 40 GHz	> 14 dB to 20 GHz > 10 dB to 40 GHz	13 ± 1.0 dB	< 1.2 dB to 20 GHz < 1.9 dB to 40 GHz
87301E	2 to 50 GHz	> 13 dB to 26.5 GHz > 10 dB to 50 GHz	10 ± 1.0 dB	< 2.0 dB
773D	2 to 18 GHz	> 30 dB to 12.4 GHz > 27 dB to 18 GHz	20 ± 0.9 dB	< 0.9 dB

Broadband couplers are also available from manufacturers below

Narda Microwave-East. www.nardamicrowave.com

Krytar. www.krytar.com

Quinstar Technology Inc. www.quinstar.com

Agilent calibration kits

Agilent offers a variety of mechanical calibration kits ranging from DC to 110GHz. For more information, refer to URL:

www.home.agilent.com/agilent/product.jsp?cc=US&lc=eng&ckey=1000000298:eps:g:pgr&nid=-536902686.0.00&id=1000000298:eps:g:pgr&pselect=SR.GENERAL#16

References

- [1] Agilent Application Note 183 High Frequency Swept Measurements, December 1978
- [2] Scalar Measurement Fundamentals, Hewlett Packard's Scalar Measurement Seminar
- [3] Scalar Measurements with the ESA-L1500A 1.5 GHz Spectrum Analyzer and Tracking Generator, Product Note, literature number 5966-1650E

Related Agilent Literature

Publication title	Pub number
<i>Agilent N1911A/N1912A P-Series Power Meters and N1921A/N1922A Wideband Power Sensors Data Sheet</i>	5989-2471EN
<i>Agilent U2000 Series USB Power Sensors Data Sheet</i>	5989-6278EN
<i>Agilent E4416A/E4417A EPM-P Series Power Meters and E-Series E9320 Peak and Average Power Sensors Data Sheet</i>	5980-1469E
<i>Agilent N1913A and N1914A EPM Series Power Meters Data Sheet</i>	5990-4019EN
<i>Agilent E4418B/E4419B EPM Series Power Meters, E-Series and 8480 Series Power Sensors Data Sheet</i>	5965-6382E
<i>Agilent N8480 Series Thermocouple Power Sensors Data Sheet</i>	5989-9333EN
<i>Agilent Choosing the Right Power Meter and Sensor Product Note</i>	5968-7150E
<i>Agilent Fundamentals of RF and Microwave Power Measurements Application Notes 1449-1/2/3/4</i>	5988-9213/4/5/6EN
<i>Agilent P-Series Power Sensor Internal Zeroing and Calibration for RF Power Sensors Application Note</i>	5989-6509EN
<i>Agilent Maximizing Measurement Speed Using P-Series Power Meters Application Note</i>	5989-7678EN
<i>Agilent RF and Microwave Test Accessories Selection Guide</i>	5990-5499EN

Appendix

For your reference, this appendix shows the SCPI commands used in the demonstration software to control the signal generator and power meter for automated scalar network analysis.

Configure the U2000 Series USB sensor:

```
SYST:PRES           //Preset the sensor
Wait for 1s
INIT:CONT OFF       //Set to single trigger
SENS:MRATE NORM     //Set to normal measurement rate
SENS:AVER:COUN 1    //Set filter length to one
SENS:AVER ON        //Turn on averaging
CAL:ZERO:TYPE EXT   //Set to external zeroing
CAL                 //Zeroing the sensor
while value not equals to zero
{
    value = STAT:OPER:CAL:COND?    //Return 0 when zeroing completed
}
```

Configure signal generator:

```
SYST:PRES           //Preset the instrument
Wait for 1s
POW:LEVEL 10DBM     //Set source power to 10 dBm
OUTP:STAT ON        //Turn on source power
```

Step through a range of frequency using these commands to perform scalar frequency sweep measurement:

```
FREQ 1GHz           //Send this command to source to set source frequency to 1 GHz
SENS:FREQ 1GHz      //Send this command to sensor to set sensor frequency to 1 GHz
READ?               //Send this command to sensor to read the input power of sensor
```

Move to next frequency point and repeat above steps.



Agilent Email Updates

www.agilent.com/find/emailupdates

Get the latest information on the products and applications you select.



www.axistandard.org

AdvancedTCA® Extensions for Instrumentation and Test (AXIe) is an open standard that extends the AdvancedTCA® for general purpose and semiconductor test. Agilent is a founding member of the AXIe consortium.



www.lxistandard.org

LAN eXtensions for Instruments puts the power of Ethernet and the Web inside your test systems. Agilent is a founding member of the LXI consortium.



<http://www.pxisa.org>

PCI eXtensions for Instrumentation (PXI) modular instrumentation delivers a rugged, PC-based high-performance measurement and automation system.

Agilent Channel Partners

www.agilent.com/find/channelpartners

Get the best of both worlds: Agilent's measurement expertise and product breadth, combined with channel partner convenience.



Agilent Advantage Services is committed to your success throughout your equipment's lifetime. We share measurement and service expertise to help you create the products that change our world. To keep you competitive, we continually invest in tools and processes that speed up calibration and repair, reduce your cost of ownership, and move us ahead of your development curve.

www.agilent.com/find/advantageservices



www.agilent.com/quality

For more information on Agilent Technologies' products, applications or services, please contact your local Agilent office. The complete list is available at:

www.agilent.com/find/contactus

Americas

Canada	(877) 894 4414
Brazil	(11) 4197 3500
Mexico	01800 5064 800
United States	(800) 829 4444

Asia Pacific

Australia	1 800 629 485
China	800 810 0189
Hong Kong	800 938 693
India	1 800 112 929
Japan	0120 (421) 345
Korea	080 769 0800
Malaysia	1 800 888 848
Singapore	1 800 375 8100
Taiwan	0800 047 866
Other AP Countries	(65) 375 8100

Europe & Middle East

Belgium	32 (0) 2 404 93 40
Denmark	45 70 13 15 15
Finland	358 (0) 10 855 2100
France	0825 010 700*
	*0.125 €/minute
Germany	49 (0) 7031 464 6333
Ireland	1890 924 204
Israel	972-3-9288-504/544
Italy	39 02 92 60 8484
Netherlands	31 (0) 20 547 2111
Spain	34 (91) 631 3300
Sweden	0200-88 22 55
United Kingdom	44 (0) 118 9276201

For other unlisted Countries:

www.agilent.com/find/contactus

Revised: October 14, 2010

Product specifications and descriptions in this document subject to change without notice.

© Agilent Technologies, Inc. 2011
Printed in USA, April 28, 2011
5990-7540EN

