

Keysight Technologies

RF and Microwave Power Meters
and Sensors for Radar Testing

Application Note



Introduction

Choose the right RF and microwave power measurement product for every stage of the radar lifecycle, from R&D through refurbishment and repair.

Many types of power meters and sensors are available today, so it is important to find products with the measurement capability and accuracy required for a given application. As a long-time manufacturer of power measurement tools for the aerospace/defense industry and as a user of these products as well, Keysight Technologies, Inc. has valuable knowledge to share and can help you make the right choice for your radar application. In this application note, we describe the various types of power meters and sensors available today and weigh the pros and cons of each in radar measurement applications.

Our discussion covers the following topics:

- A review of the basic parameters of a radar system and key power measurements
- The three common power sensor technologies—thermocouple, thermistor, and diode—and their use in testing current and future radar systems
- Criteria for selecting the best power meters and sensors for radar applications
- Advanced power measurement techniques enabled by software.

We conclude with a look at some real-world scenarios that demonstrate the time and cost savings of software-enhanced power meter/power sensor solutions. A list of related literature and links to selection tables and other useful web tools are included.

Abstract

RF and microwave power output is a critical factor in the design and subsequent performance of radar systems. Power measurements are required at every stage of the radar system lifecycle. Often the most cost-effective way to make power measurements is with power meters and power sensors. Because these instruments are relatively inexpensive and easy to use, they are ubiquitous across the radar lifecycle for testing in R&D, manufacturing, maintenance, and repair applications.

Characterizing the Power and Timing of Radar Pulses

Let's begin by reviewing the basics of a radar system and the key power and timing requirements. A radar system transmits a microwave signal, sweeping it through a region of interest known as the target space. A target is detected when it is within the line of sight of the transmit antenna and the signal is reflected (echoed) from the target back to the radar system. If the reflected signal is strong enough to rise above the radar system's noise floor, the radar compares the transmitted signal to the reflected signal and determines such things as the range, resolution, and velocity of the target. A simple radar block diagram is shown in Figure 1.

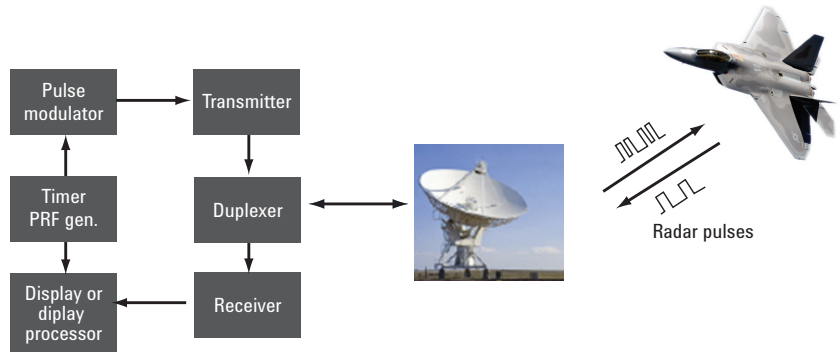

Figure 1. Block diagram of a simple radar system

The output power from a radar transmitter is one of the most important factors in determining the performance of the radar system. For example, the range or maximum distance at which a target can be detected by the radar relates directly to the pulse power of the transmitted signal. Accurate power measurements are required of all radar systems to ensure that the radar system meets its specifications.

Other characteristics of the pulse shape and timing similarly affect radar performance. As shown in Figure 2, these include pulse width, pulse transition time, pulse repetition frequency (PRF), pulse repetition interval (PRI), duty cycle, peak power, and average power.

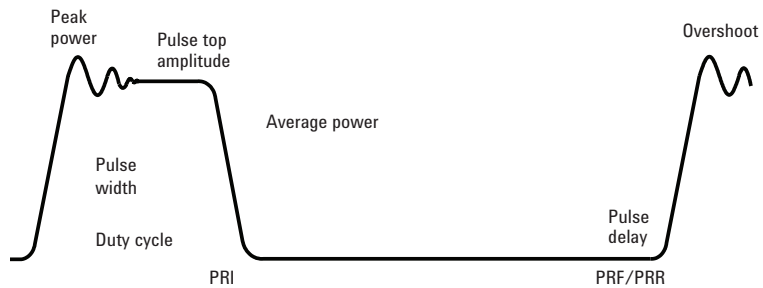

Figure 2. Typical radar pulse characteristics

The list below summarizes the importance of a few of these parameters:

- Pulse power determines the range of the radar signal.
- Pulse repetition interval (PRI)—the elapsed time from the beginning (transmission) of one pulse to the beginning of the next pulse—is used in determining the maximum unambiguous range of the target. During this process, the first pulse must travel to the target and back before the next pulse is sent.
- Pulse width is used in determining the resolution of the radar system. The pulses must be shorter than the time it takes to travel between the targets; otherwise, the received pulses will overlap in the radar receiver.
- Pulse transition (rise and fall) time affects system bandwidth. The faster the rise and fall time, the wider the bandwidth. Wide system bandwidth, however, creates more noise at the receiver and decreases sensitivity. The chance of exceeding the regulated frequency allotment also increases.

Radar pulse characteristics are defined in IEEE 181-2003, *Standard on Transitions, Pulses, and Related Waveforms*. This standard replaced the earlier IEEE 181-1977 and IEEE 194-1977 and is the current standard on which power measurements are based. By accurately characterizing radar pulses in conformance with the standard, we can learn a great deal about a radar system's capability and limitations. This knowledge allows us to be sure that the radar system is working properly. Keysight's power meters and sensors, previewed in Table 1, meet these standards.

Power meters used with power sensors are a good choice for measuring radar pulse characteristics in many applications. In general, power meters are chosen to match a user's measurement data requirements, while the power sensors are chosen to match the signals and modulation types. Today's power meters provide accurate RF power results, typically in the range of ± 0.2 dB. Such accuracy is possible because the meters and sensors are characterized by the manufacturer and correction factors are applied to remove any non linearities that may arise during conversion from RF power to DC voltage.

Keysight's power meters and sensors cover broad frequency ranges extending from a few kHz to 110 GHz and are capable of measuring the majority of today's radar systems. Uncertainty factors for the meters and sensors are published and can be analyzed to determine the total margin of error of a particular measurement setup. To simplify this task, Keysight provides uncertainty calculators for its power meters and sensors, available for free download by searching "uncertainty calculator" at www.keysight.com. Measurements provided by the power meters are traceable to national and international standards laboratories including the U.S. National Institute for Standards and Technology (NIST) and the National Physical Laboratory (NPL) in the U.K.

Perhaps the most basic reason for choosing power meters and sensors in radar applications is their reputation for relatively low cost and ease of use. The right power meter and sensor combination can meet nearly all of an engineer's radar power measurement needs, including pulse power, average power, rise time, PRF, pulse width, and peak-to-average ratio measurements and even power statistics. The first step in choosing the right measurement products is to understand the power sensor technology and how it fits with the specific application for which it will be used.

Table 1. Overview of Keysight power meters and sensors for radar applications

Sensor technology	Keysight model	Compatible power meter	Power range	Frequency range	Type of power measurement		
					CW power	Pulse power ¹	Pulse profile ²
					Typical applications		
					CW radar	Radar/navigation	Radar/navigation
Thermocouple and diode sensor	8480/N8480 series	EPM, EPM-P, P-Series	-35 to +44 dBm	100 kHz - 70 GHz	•	•	
Single diode pair sensor compensated for extended range	E4412/13A	EPM, EPM-P, P-Series	-70 to +20 dBm	10 MHz - 33 GHz	•		
Two path diode stack sensor	E9300 series	EPM, EPM-P, P-Series	-60 to +44 dBm	9 kHz - 24 GHz	•	•	
Average USB sensor diode stack	U2000	Not applicable	-60 to +44 dBm	9 kHz - 26.5 GHz	•	•	
Peak and average sensor (VBW < 5 MHz)	E9320 series	EPM-P, P-Series	Average: -65 to +20 dBm Peak: -45 to +20 dBm	50 MHz - 18 GHz	•	•	•
Peak and average sensor (VBW < 30 MHz)	N1921/22A	P-Series	Average/Peak: -35 to +20 dBm	50 MHz - 40 GHz	•	•	•

1. Average power meters enable pulse power measurements by means of the duty cycle method. The pulse power can be calculated using the measured average power divided by its duty cycle. The pulse power will be equivalent to the peak power for a perfectly rectangular pulse.
2. Peak power meters make peak envelope power and pulse parameter measurements such as rise and fall time, pulse width, pulse period, duty cycle, etc.

Understanding the Types of Power Sensors

Power sensors convert high frequency power to a DC or low frequency signal that can be measured and related to an RF or microwave power level through calibration. Different types of sensor technology are in use today: heat-based sensors such as thermistors and thermocouple sensors, and diode-detector-based sensors. Each has advantages and limitations for radar system use.

Heat-based sensors absorb RF and microwave energy and sense the resulting rise in heat. These sensors are independent of the waveform and thus respond to the true average power of the signal, regardless of its modulation format. Diode-based sensors depend on the rectifying characteristics of their microwave detection curve. They can measure power down to -70 dBm, which makes them suitable for ultra-low signal detection applications as well as for wide dynamic range measurements. Diode-based sensors also have a faster response time, which makes them useful for pulse and high data rate applications.

Thermistor sensors

A thermistor is a type of semiconductor whose resistance varies with temperature. When the temperature rises, the resistance decreases. The operation of thermistor sensors is based on a balanced bridge technique whereby the thermistor element maintains a constant resistance R by means of DC or low frequency AC bias. As the RF power in the thermistor dissipates, which tends to increase R , the bias power is withdrawn by an equal amount to balance the bridge and keep R at the same value. That decrement in bias power is measured and displayed on a meter to indicate RF power. See Figure 3.

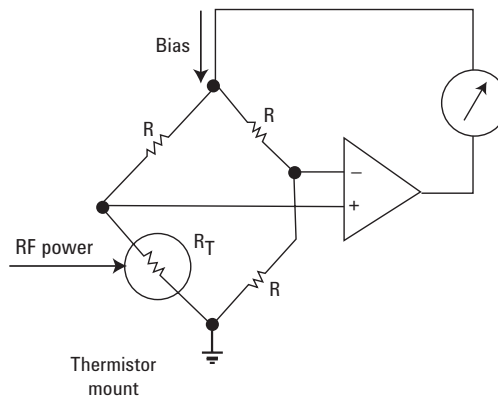

Figure 3. Bridge technique used in thermistor sensor

Thermistors were one of first sensor technologies used to measure RF and microwave power. They are limited, however, by low sensitivity and are good down to about -20 dBm. Thermistors are also subject to ambient temperature drift, although modern thermistors use compensation techniques to overcome this drawback. Thermistor measurement speed is relatively slow, dictated by the thermal time constant.

Over time thermistor sensors have been replaced in radar applications by thermocouple and diode-based sensors, which have greater sensitivity, wider dynamic range, and higher power capabilities. Nevertheless, because thermistor sensor technology is based on the highly precise DC substitution technique, these sensors are still used in metrology labs for calibrating the thermocouple and diode-based sensors used in radar applications. Radar measurements need to be very accurate, and the special use of a thermistor sensor (such as the Keysight 478A thermistor mount) as a power transfer standard is accepted by NIST and other standards labs. Thus the thermistor sensor provides critical traceability from the engineer or technician's radar power measurement back to the fundamental power standard.

Thermocouple sensors

Thermocouple sensors are heat-based averaging detectors that are based on the principle that two dissimilar metals will respond to different temperatures at their “hot” and “cold” junctions by generating voltages. See Figure 4. If the two metals are put together in a closed circuit, current will flow due to the difference in voltages. If the loop remains closed, the current will continue to flow as long as the junctions remain at different temperatures. In a thermocouple element, the loop is broken and a sensitive voltmeter is inserted to measure the thermoelectric voltage of the loop. The voltage is proportional to the temperature change resulting from the RF power incident on the thermocouple element. Modern thermocouple technology is an evolution of this technique. It takes advantage of semiconductor and thin-film technologies to create highly accurate, rugged sensors that can be used in high frequency power measurement. Examples are the Keysight 848xA and N848xA series of thermocouple sensors.

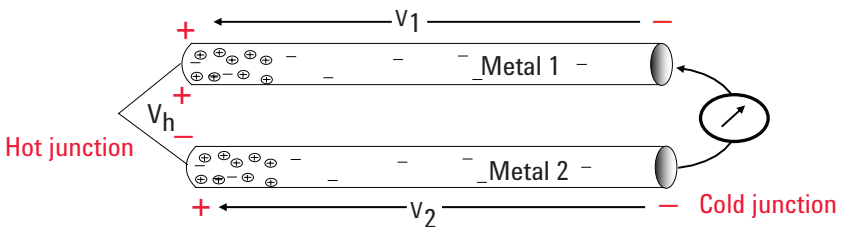

$$V_0 = V_2 + V_H - V_1$$

Figure 4. In a thermocouple sensor, the temperature difference between the hot and cold junctions of dissimilar metals generates a voltage, which is proportional to the temperature change.

Because thermocouple sensors respond to the true power of a signal, they provide very accurate average measurements and are ideal for all types of signal formats. Historically these sensors have been chosen for testing complex modulation systems, including radars, because test engineers can be assured that the sensors respond to the total aggregate power across their entire dynamic range. In this case a radar’s peak power can be computed from the average power value and a knowledge of the radar system’s duty cycle. The ability to compute average power from duty cycle is provided as part of the Keysight power meters.

Thermocouple sensors are rugged, stable, and reliable. However, they have limited dynamic range, typically 55 dB, from -35 dBm ($0.32 \mu\text{W}$) to $+20$ dBm (100 mW). For low power measurements or for very low duty cycle pulse power measurements, a more sensitive diode-based sensor may be required.

Diode sensors

Unlike thermocouple sensors, diode-based sensors do not measure the heat content of a signal but instead rectify the signal, converting high frequency energy to DC by means of the diode's non-linear current-voltage characteristics. Figure 5 shows the rectification characteristics of a diode detector. In the square law region, the diode's detected output voltage is linearly proportional to the input power, and power can be measured directly. The square law region extends from approximately -70 dBm to -20 dBm, giving a dynamic range of 50 dB. Above -20 dBm, the square law is no longer valid and correction factors must be applied to ensure accurate power measurements. The stable characteristics of modern diode detectors allow the use of data compensation and correction techniques that can provide up to 90 dB of dynamic range. Different types of diode-based sensors have been developed and have different uses in radar testing.

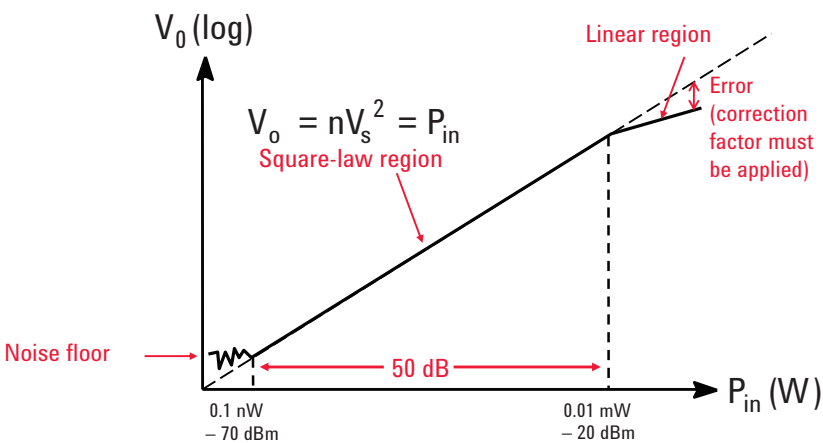

Figure 5. Diode detection ranges from the square law region to a linear region, where correction factors are applied.

CW-only diode sensors

Wide dynamic range, CW-only sensors can accurately measure CW signals from -70 to $+20$ dBm. To achieve the expanded dynamic range of 90 dB, a CW-only sensor depends on a data compensation algorithm that is calibrated and stored in an EEPROM in the sensor. Information is stored for three parameters—input power level, frequency, and temperature—for the sensor's specified ranges. When the power sensor is turned on, this calibration information is uploaded automatically to the power meter attached to the power sensor. A temperature sensor on the power sensor's diode supplies temperature data for the temperature-compensation algorithm in the power meter. This enables a single sensor to accurately measure CW signals across the 90 dB range, performing a task that previously required two sensors.

Figure 6 shows a simplified schematic of the Keysight E4412A and E4413A power sensors, which use the CW compensation technique and are used to accurately measure average power in CW radar signals. These sensors should not be used for modulated radar signal such as Doppler or pulsed radar signals.

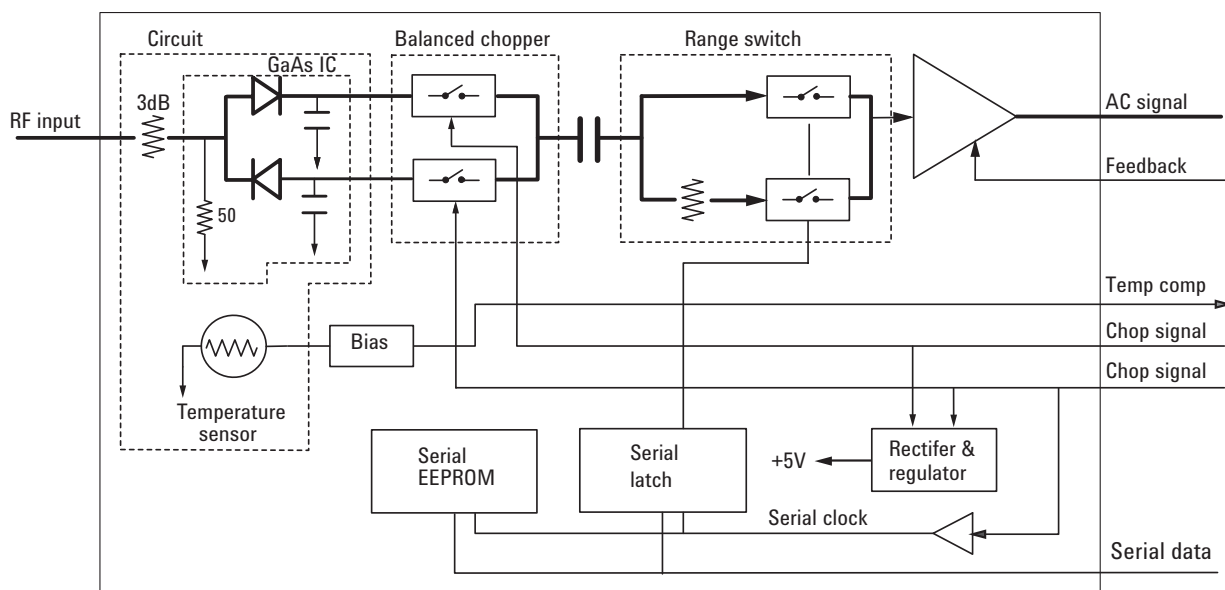

Figure 6. The power sensor's EEPROM stores linearity, temperature compensation, and calibration factor corrections that are used to achieve a 90 dB power range.

Two-path diode-stack sensors

Radar pulse signals often contain many frequency components. It is not possible to characterize this type of signal accurately using a CW-only sensor. For such non-CW signals, a better choice for power measurement is a wide dynamic range, two-path diode stack sensor. This type of sensor provides up to 80 dB of dynamic range using a two-path design with separate paths for the low power and the high power. The design is based on a diode-attenuator-diode topology that maintains the sensing diodes within their square law region and thus ensures a correct response to complex modulation formats.

Figure 7 shows this sensing element in a Keysight E9300 series sensor. Each diode stack forms a measurement path, with the high power path ranging from -10 dBm to $+20$ dBm and the low power path from -60 dBm to -10 dBm. Only one path is active at a time, and switching between the paths is fast, automatic, and transparent to the user, effectively producing an 80 dB dynamic range.

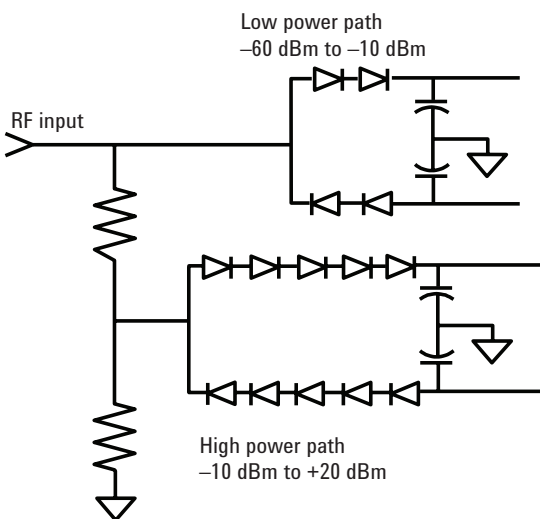

Figure 7. Schematic of a diode-attenuator-diode sensing element

There are two types of two-path diode sensors: averaging and peak. Averaging sensors have wide dynamic range and measure the average power of a modulated signal. They include the Keysight E9300 series shown above as well as the Keysight U2000 series.

Peak and average power sensors

Peak power sensors can measure average power, but they can also measure the modulation waveform so that a test engineer can measure the actual peak power and average power of a radar pulse over time. Often called “peak and average” power sensors, peak power sensors are designed for characterizing pulsed and complex modulation formats. Because these diode sensors make fast measurements, they are well suited for measuring peak envelope power and pulse parameters, including transition duration (aka rise and fall time), pulse width, pulse period, and duty cycle. Typical peak power sensors have two-mode operation, “normal” for both peak and average power measurements and “average only” for average power measurements. This is shown in Figure 8. Examples include the Keysight N192xA and E932xA power sensors.

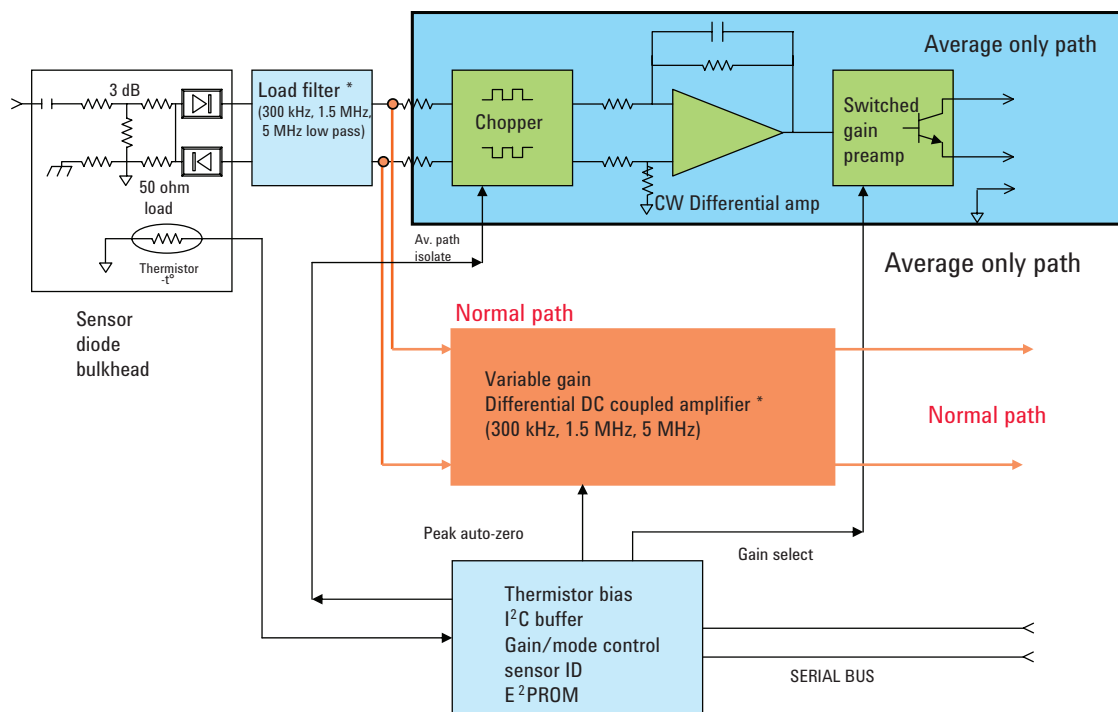

Figure 8. Block diagram of a peak and average sensor showing the parallel amplification paths, one for “average only” and one for “normal” (peak power measurements).

Diode sensor comparison

Figure 9 compares the performance of three types of power sensors in a pulse power measurement. In this example a signal with a pulse width of 50 μs and pulse period of 1 ms is measured. The signal is swept from -56 dBm to +20 dBm. The X-axis on the graph shows the average power that goes into the power sensor. This average power can be calculated from the pulse power using the equation $10 \cdot \log(\text{PW}/\text{PP})$ or $10 \cdot \log(\text{duty cycle})$, which translates to 13 dB down from the pulse power. Thus the average power going into the sensor is -69 dBm to +7 dBm. The error in dB is shown on the Y-axis.

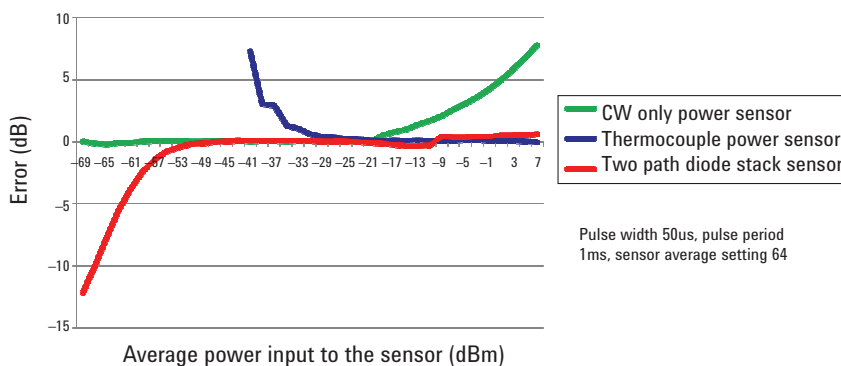

Figure 9. Comparison of three sensor types for pulse power measurement

The CW-only power sensor shows a high error above -20 dBm, which is expected since CW-only sensors are designed for single frequency measurements. When operating in the square law region (below -20 dBm), the CW-only sensor provides good accuracy.

The thermocouple sensor offers the highest accuracy but only down to about -35 dBm. Accuracy at the lower power range could be further improved by setting a higher average.

The two-path diode stack sensor offers good accuracy down to -60 dBm with the highest dynamic range.

Summary of power sensor ranges and applications

Figure 10 shows the power ranges offered by all the sensor types. Thermistor sensors, although they have the highest accuracy, have a limited operating range from -20 dBm to $+10$ dBm. Thermocouple sensors cover a wider range and are true average power responding from -35 dBm to $+20$ dBm, and to $+44$ dBm using an attenuator. Diode-based sensors have the best sensitivity, operating well down to -70 dBm, but as noted begin to deviate when used above -20 dBm. Wide dynamic range power sensors are diode sensors that achieve a 90 dB dynamic range by correcting the deviation with a CW source or by implementing a two-path diode-stack topology to measure modulated signals. Wide dynamic range measurements can be made to a maximum of $+44$ dBm using an external attenuator.

Keysight recommends the use of high power sensors such as the “H” and “B” sensors for measuring power levels up to $+44$ dBm. These high power sensors use an external attenuator that is calibrated with the sensor, and this sensor topography ensures the highest possible accuracy. However, Keysight does not recommend the use of low power sensors with general purpose attenuators. In such cases the general purpose attenuator will cause significant measurement error because the attenuator is not calibrated with the sensor and the setup does not compensate for mismatch and losses between the attenuator and sensor.

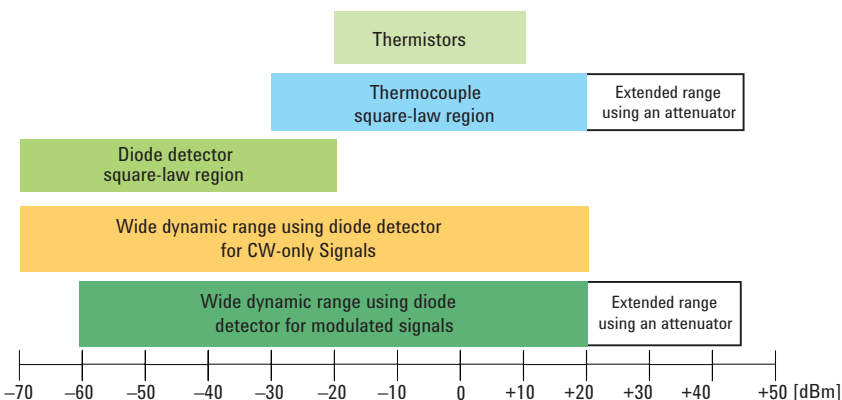

Figure 10. Power range of various sensor types

As discussed, thermocouple sensors are rugged and provide stable, reliable measurements. In many radar applications, thermocouple power sensors are used for average power measurements while the diode detector is used if peak power or pulse parameter measurements are required. Please refer to Table 1 for Keysight sensor products that correspond to the technologies in Figure 10.

Choosing the Right Power Meter

Power meters are chosen to match the measurement requirements of an application and are usually categorized as average or peak power meters. (Peak power meters, like the peak power sensors just discussed, are often called “peak and average” power meters because they have the ability to make both kinds of measurements.) Examples of average power meters are the Keysight N1913A and N1914A meters and U2000 series of USB sensors. The Keysight N1911A and N1912A P-series and E4416A and E4417A are examples of peak and average power meters. Each type has specific measurements, features, and performance capabilities that suit a variety of radar pulse measurement requirements. Examples are shown in Figure 11.

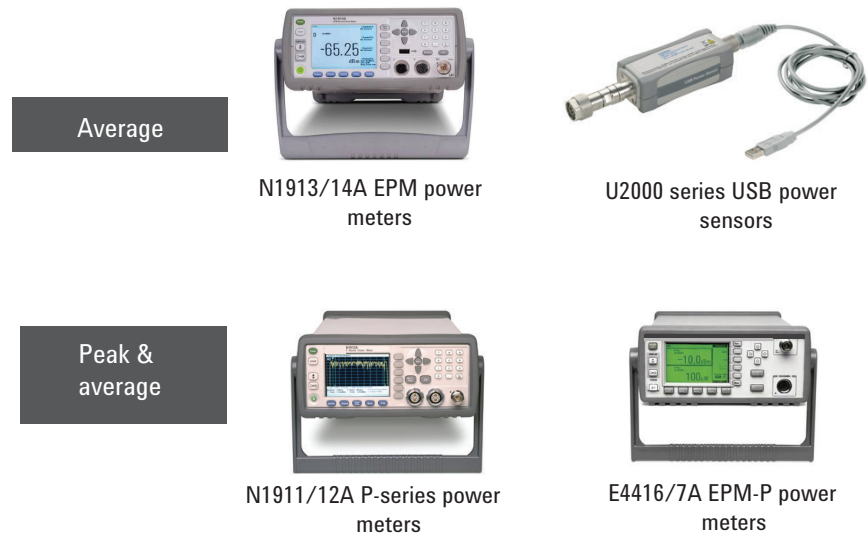

Figure 11. Examples of Keysight power meters

Average power meters

Average power meters, such as the EPM series, can make pulse power measurements using the duty cycle method. With this method, pulse power is calculated by dividing the measured average power by the pulse duty cycle. The result is a mathematical representation of the pulse power and assumes constant peak power. The pulse power averages out any aberrations in the pulse such as overshoot or ringing. To ensure accurate pulse power readings, the input signal must be a repetitive, rectangular pulse of constant, known duty cycle. Other pulse shapes—for example, triangular or Gaussian—will cause erroneous results. Also the method is not applicable for digital modulation systems in which duty cycle is not constant nor for pulses of variable amplitude or shape.

The duty cycle method has several advantages:

- Lowest cost, as average power meters and sensors are less expensive than peak power meters and sensors
- Ability to measure over a wider dynamic range and a wider frequency range, with average power sensors available from 9 kHz to 110 GHz
- Easiest way to measure rectangular pulses, with only the duty cycle required as input to obtain pulse power results.

Figure 12 shows the measurement of a pulse signal with a pulse width (PW) of 10 μ s and a pulse period (pulse repetition interval or PRI) of 40 μ s. The signal is set with a power level of approximately 0 dBm. Using an average power meter to measure the average power of the signal gives a result of -6.29 dBm. The duty cycle, which is PW/PRI or 10 μ s divided by 40 μ s, equal to 25%. This value is entered into the power meter to obtain a pulse reading of -0.28 dBm.

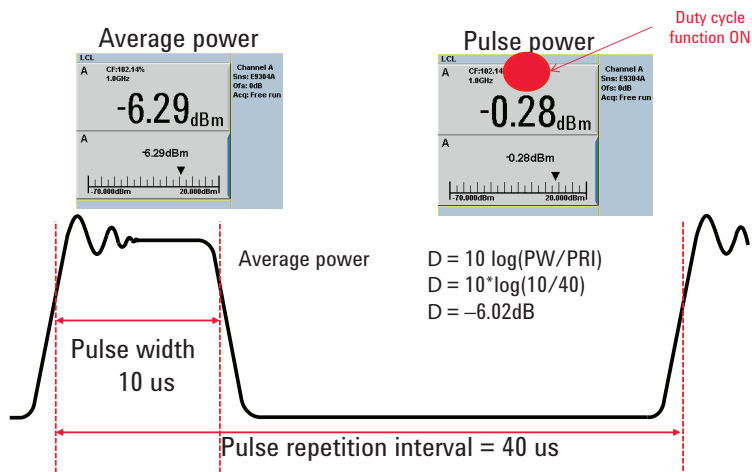

Figure 12. Calculating pulse power using the duty cycle method

The equation shown in Figure 12 is used by the power meter to calculate the difference between pulse power and measured average power. The result is a value in which the pulse power is 6.02 dB higher than the average power. As the figure suggests, however, the pulse may not be purely rectangular. There is an associated rise and fall time as well as possible overshoot on the signal. The combination of these effects will create an error in the calculated result. A more accurate method of determining the peak power in this case is with a peak power meter.

Peak power meters

Highly sophisticated radar and navigation systems, which are often based on complex pulsed and spread spectrum technologies, require more sophisticated instruments for characterizing pulsed RF power. Peak power meters offer a number of advantages for this task:

- Ability to measure both peak and average power
- Trace capability to see the measurements being made
- Pulse parameters such as peak-to-average power, peak power, rise and fall time, etc.
- Ability to measure peak envelope power—no duty cycle calculations are needed
- Ideal for single-shot measurements on non-repetitive signals

Peak power meters measure both peak and average power, and they can display the pulse power envelope so that a test engineer can view the power measurements as they are made. Examples of peak power meters are the Keysight EPM-P and P-series power meters, which use a continuous sampling technique that measures peak power over a defined time period rather than using a calculation. This technique allows accurate measurement of peak power on non-rectangular pulses and also allows single-shot measurement of non-repetitive signals. Continuous sampling also allows for digital filtering architecture and bandwidth correction within the power meter. Digital filtering enhances the dynamic range of the power meter/sensor combination, and bandwidth correction provides optimal accuracy for peak and statistical power measurements.

In selecting a peak power meter, it's important to consider the dynamic range and frequency range specifications, which may be narrower than those of average power meters. Two other important specifications for peak power meters are the sampling rate and video bandwidth. The sampling rate must be sufficient to accurately measure and display characteristics of the radar pulse signals such as rise time, fall time, and pulse width.

Sampling rate and video bandwidth

The sampling rate in peak power meters is related to video bandwidth, just as it is in a digital oscilloscope. According to the Nyquist theorem, the sampling rate must be more than twice the maximum signal bandwidth in order to build an accurate waveform. In practice, a factor of 4 or less is used to determine the video bandwidth. Therefore, the higher the sampling rate, the wider the video bandwidth, so that the power meter can capture and measure a fast rise time or fall time on a radar pulse. Keysight's P-series peak power meters, for example, have a real time sampling rate of 100 MSamples/s with a flat video bandwidth of 30 MHz, shown in Figure 13. These power meters can make very accurate rise and fall time measurements down to 40 ns with an error of less than 5%.

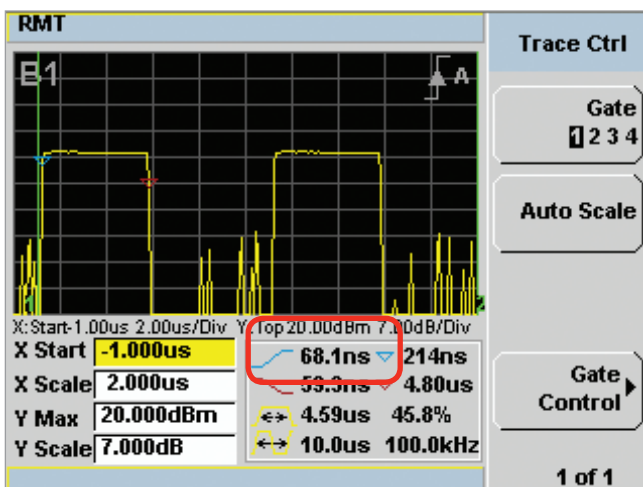

Figure 13. A peak power meter uses continuous sampling and 30 MHz video bandwidth to accurately measure fast rise and fall times.

To determine the video bandwidth that is required for a radar pulse measurement, we can use a rule-of-thumb calculation that is accepted in the industry. First, determine the signal's fastest rise time (t_r). Some standards specify rise time from a 10% threshold to the 90% threshold, for example, while others specify a 20% to 80% threshold.

Next, calculate the highest frequency component of the signal, also known as the signal bandwidth (BW_{signal}), as follows:

- $BW_{\text{signal}} = 0.5/t_r$ (10% to 90% threshold)
- $BW_{\text{signal}} = 0.4/t_r$ (20% to 80% threshold)

Now calculate the video bandwidth of the power meter ($BW_{\text{powermeter}}$) that is required to avoid attenuating any of the signal's frequency components:

- $BW_{\text{powermeter}} = 2 * BW_{\text{signal}}$ (for Gaussian frequency response)
- $BW_{\text{powermeter}} = 1.4 * BW_{\text{signal}}$ (for maximally flat response)

Both equations give a rise time measurement accuracy of approximately 3%. If the signal bandwidth calculated using the formula above exceeds the video bandwidth of the peak power meter, then by implication the error of the measurement will be greater than the suggested 3%.

Useful automation features

Several automation features on peak power meters are particularly useful for making radar pulse measurements.

- *Automated pulse characterization measurements* eliminate the need for tedious manual measurement setup. Measurement automation requires a power meter with an auto scale function and the ability to automatically set up and display rise time, fall time, pulse width, PRI, and PRF measurements.
- *Time-gated power measurements* require a power meter with an auto gate function that automatically places a pair of gates around a pulse ON period when the function is turned on. This feature allows peak, average, and peak-to-average power ratio measurements on any selected pulse. The power meter should also support pulse droop measurements
- *Measurement presets* greatly simplify measurement setup. Based on the selected preset, parameters such as frequency, power, time scale, triggering, display format, and time gates are configured automatically. Figure 14 shows some examples of measurement presets for applications on a Keysight power meter. These include radar, DME, and DME-PRT.

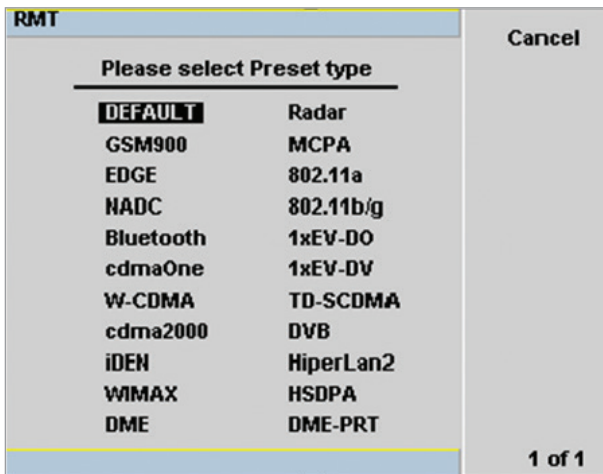

Please select Preset type	
DEFAULT	Radar
GSM900	MCPA
EDGE	802.11a
NADC	802.11b/g
Bluetooth	1xEV-DO
cdmaOne	1xEV-DV
W-CDMA	TD-SCDMA
cdma2000	DVB
iDEN	HiperLan2
WIMAX	HSDPA
DME	DME-PRT

Figure 14. Measurement presets include options for radar and DME.

These and other key features are available on Keysight’s average and peak power meters. For more detailed descriptions, please see the additional information section at the end of this note.

Selection table

For help in selecting the best power meter and power sensor combination for your radar power measurements, please refer to Table 1 on page 5.

Using Software to Make Advanced Measurements

Power measurement instruments are no longer merely a combination of hardware. Today's PC-based software can extend the computation and analysis capabilities of power meters and sensors, adding new features for pulse characterization and analysis and power statistics analysis in a variety of formats. These capabilities are especially valuable in radar power applications, which present many challenges for test engineers due to the transient nature of radar pulses and the complexity of modern pulse-compression schemes. Keysight's N1918A Power Analysis Manager software, for example, loads a complete set of pulse parameter measurements when the pulse characterization function is turned on (Figure 15).

Keysight offers two versions of its powerful software tool. Power Panel is a free version that comes bundled with the power measurement instruments and provides a PC measurement display with graphical functions such as markers, auto-scaling, and zooming; save and load functions; and instrument setup options including settings for time-gated measurements and instrument presets. Power Panel overcomes the limitations of small power meter displays and allows more parameters to be shown.

Power Analysis Manager is the full version of the N1918A and a licensed product. In addition to graphical and file handling capabilities, this software includes comprehensive functions to extend and automate pulse characterization, statistical analysis, data logging, limits, and alert notification. In Figure 15, Power Analysis Manager is able to set up and display 21 pulse parameters and gated measurements.

21 automatic pulse parameters and gated measurements

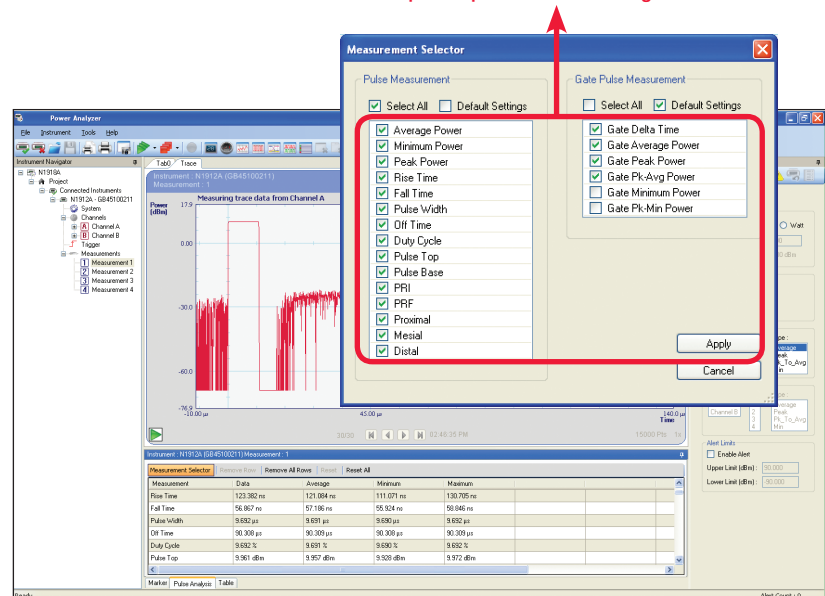

Figure 15. Power analysis software sets up and displays a comprehensive set of radar power measurements.

Pulse-to-pulse measurement in an air traffic control radar beacon system

Pulse-to-pulse measurement applications such as maintaining an air traffic control radar beacon system (ATCRBS) transponder require the ability to measure two channels, one for the interrogation pulse and one for the reply pulse. The maintenance task begins by validating each of the interrogation and reply pulse characteristics and making sure that the pulses meet specification. Typically a dual-channel power meter is used to make these measurements, displaying the results for each channel in a separate window as shown in Figure 16.

Using an overlay feature in the N1918A Power Analysis Manager with the dual-channel meter allows the two pulses to be combined into a single time domain display, shown in Figure 17. Overlaying the pulses makes it much easier to compare and analyze the pulse characteristics using functions such as markers. Parameters that are required for maintenance and calibration, such as the power level between pulses (delay between the interrogation and reply), can be quickly and accurately determined.

Other uses for the analysis software include comparison of input and output power statistics in amplifier tests and comparison of the measured pulse to a reference pulse or other known good signal.



Typical dual channel power meter display

Figure 16. Typical dual-channel power meter displays the interrogation and reply pulses separately.

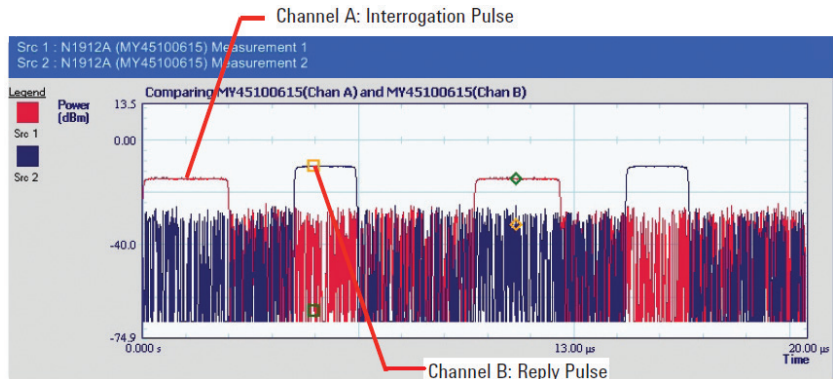

Overlay graph

Figure 17. Software-enabled overlay function combines the interrogation and reply pulses for easier comparison and analysis.

Monitoring radar power with Keysight USB power sensors

The Keysight U2000 series of diode power sensors are USB-based average power sensors that display power measurement readings on a PC or other Keysight instrument without the need for a separate power meter. The USB sensors measure pulse power using the duty cycle method. Alternatively, the sensors can be set to make time-gated measurements of pulse power by placing a pair of gates around the pulse during the pulse ON time. These two measurement approaches will give similar results for perfectly rectangular pulses.

The USB sensors are particularly useful for field applications including the maintenance, service, or repair of a radar system. In one real-life example, a user is testing the performance of a radar system on board an aircraft. To verify the stability of the radar's output power over time, ten USB sensors are placed at various locations on the aircraft and each is programmed to collect a data point every second. Thus ten data points are collected simultaneously every second, with the monitoring process continuing over a period extending to days and eventually to months. Power can be measured while the aircraft is stationary or in the air.

For this application, the power sensors themselves must be very accurate to ensure that the customer is measuring the stability of the radar system, not of the measurement equipment. Additionally, the measurement data must be captured, stored, and processed very quickly. Data from the ten sensors is fed back to a single PC running the N1918A Power Analysis Manager software. The N1918A enables the simultaneous monitoring of all channels on the PC and records all the captured data. Power measurements can be replayed for offline analysis. If the radar pulse power exceeds prescribed limits, the software alerts the test engineer, providing details such as measurement results, the limit setting, and a timestamp of when the event occurred. For this particularly challenging field application, the USB sensors and radar measurement software together make a powerful, easily deployed, cost-effective solution.

Conclusion

The ability to make accurate measurements of pulse power and peak envelope power is crucial in radar applications. As we've seen, today's power meters and sensors can be used with application-focused software to create comprehensive yet cost-effective solutions that perform the same work done by more complex, expensive test instruments. Choosing the right solution for a radar application requires choosing from among the various types of power sensors (thermistor, thermocouple, and diode) and power meters (average and peak). Keysight power products cover all the measurement technologies and architectures for basic and advanced, standards-based measurements.

Additional Information

More information about Keysight power meters and sensors, including an expanded selection table, is available on the web at www.keysight.com/find/powermeters. Also, please refer to the following publications:

Publication name	Literature number
<i>Keysight N1918A Power Analysis Manager, Data Sheet</i>	5989-6612EN
<i>Keysight N1911A/N1912A P-Series Power Meters and N1921A/N1922A Wideband Power Sensors, Data Sheet</i>	5989-2471EN
<i>P-Series Power Meters and P-Series Wideband Power Sensors, Configuration Guide</i>	5989-1252EN
<i>P-Series Power Meters and P-Series Wideband Power Sensors, Technical Overview</i>	5989-1049EN
<i>Keysight E4416A/E4417A EPM-P Series Power Meters and E-Series E9320 Peak and Average Power Sensors, Data Sheet</i>	5980-1469E
<i>Keysight N1913A/N1914A EPM Series Power Meters, Data Sheet</i>	5990-4019EN
<i>Keysight U2000 Series USB Power Sensors, Data Sheet</i>	5989-6278EN
<i>Keysight Radar Measurement, Application Note</i>	5989-7575EN
<i>Perfecting Pulsed RF Radar Measurements, White Paper</i>	5989-7323EN

myKeysight

myKeysight

www.keysight.com/find/mykeysight

A personalized view into the information most relevant to you.



www.axiestandard.org

AdvancedTCA® Extensions for Instrumentation and Test (AXIe) is an open standard that extends the AdvancedTCA for general purpose and semiconductor test. Keysight is a founding member of the AXIe consortium. ATCA®, AdvancedTCA®, and the ATCA logo are registered US trademarks of the PCI Industrial Computer Manufacturers Group.



www.lxistandard.org

LAN eXtensions for Instruments puts the power of Ethernet and the Web inside your test systems. Keysight is a founding member of the LXI consortium.



www.pxisa.org

PCI eXtensions for Instrumentation (PXI) modular instrumentation delivers a rugged, PC-based high-performance measurement and automation system.



Three-Year Warranty

www.keysight.com/find/ThreeYearWarranty

Keysight's commitment to superior product quality and lower total cost of ownership. The only test and measurement company with three-year warranty standard on all instruments, worldwide.



Keysight Assurance Plans

www.keysight.com/find/AssurancePlans

Up to five years of protection and no budgetary surprises to ensure your instruments are operating to specification so you can rely on accurate measurements.



www.keysight.com/quality

Keysight Technologies, Inc.
DEKRA Certified ISO 9001:2008
Quality Management System

Keysight Channel Partners

www.keysight.com/find/channelpartners

Get the best of both worlds: Keysight's measurement expertise and product breadth, combined with channel partner convenience.

www.keysight.com/find/powermeter

For more information on Keysight Technologies' products, applications or services, please contact your local Keysight office. The complete list is available at: www.keysight.com/find/contactus

Americas

Canada	(877) 894 4414
Brazil	55 11 3351 7010
Mexico	001 800 254 2440
United States	(800) 829 4444

Asia Pacific

Australia	1 800 629 485
China	800 810 0189
Hong Kong	800 938 693
India	1 800 112 929
Japan	0120 (421) 345
Korea	080 769 0800
Malaysia	1 800 888 848
Singapore	1 800 375 8100
Taiwan	0800 047 866
Other AP Countries	(65) 6375 8100

Europe & Middle East

Austria	0800 001122
Belgium	0800 58580
Finland	0800 523252
France	0805 980333
Germany	0800 6270999
Ireland	1800 832700
Israel	1 809 343051
Italy	800 599100
Luxembourg	+32 800 58580
Netherlands	0800 0233200
Russia	8800 5009286
Spain	0800 000154
Sweden	0200 882255
Switzerland	0800 805353
	Opt. 1 (DE)
	Opt. 2 (FR)
	Opt. 3 (IT)
United Kingdom	0800 0260637

For other unlisted countries:
www.keysight.com/find/contactus
(BP-07-10-14)

